

# interfloor

UNDERLAY & ACCESSORIES COLLECTION

**Duralay**  
Underlay Experts Since 1952

**tredaire**  
It's what's underneath that counts

**SONIXX**  
Performance. Comfort. Endurance.

**Gripperrods**

**STIKATAK**

Working in partnership with **ROBERTS** professional flooring tools

# One giant leap for carpet comfort



# See inside for out-of-this-world underlays

Welcome to our complete range of underlay and accessories.

Choosing the right underlay is not always easy. There are a lot to choose from and there are many factors to consider, such as comfort, durability, suitability with underfloor heating, noise reduction, warmth and more.

This catalogue will help you find exactly the right set of underlays for your store's range or the perfect underlay for a specific project or installation, along with a range of accessories you will need for the job.

# CONTENTS

		Page
About Interfloor	Our History & Heritage	4
	Why Choose Our Underlay?	6
	Our Brands	8
Underlays	Underlays Explained	10
	Backings Explained	12
	Underlay For Carpet	14
	<b>PU Carpet Underlays</b>	<b>17</b>
	<b>renu® - Planet Friendly &amp; Recycled Underlay</b>	<b>28</b>
	Sponge Rubber Carpet Underlays	30
	Crumb Rubber Carpet Underlays	36
	Crumb / Felt combination and Egalsoft® adhesive felt	38
	<b>Sonixx® Acoustic Products</b>	<b>40</b>
	<b>FR &amp; IMO Underlays</b>	<b>44</b>
	Hard Flooring Underlays	50
	Underfloor Heating Underlays	54
	<b>The Floorfixx Dry Levelling System</b>	<b>58</b>
Accessories	Gripperrods® Carpet Grippers	59
	Gripperrods® Premier Floor Edgings	64
	Gripperrods® Carpet & Vinyl Floor Edgings	68
	Gripperrods® Wood & Laminate Floor Edgings	76
	Adhesives & Tapes	80
	Heat Seaming Tapes	86
	<b>Roberts® Fitting Tools</b>	<b>88</b>
	Retail Packaged Products	116
Help and Advice	Installation Guides	120
	Support	122
Technical Information	Specification Tables	124

# OUR HISTORY & HERITAGE

## Underlay experts since 1952

When Duralay was first established in the 1950s, it marked a turning point for the industry with a brand that would remain market leader for decades to come. But our roots go even deeper than that. We can trace our history back to 1789 with the founding of a company named Durie & Miller.

Running for well over 100 years as a successful weaving company, Durie & Miller broke into the flooring market for the first time in the 1940s, seeing great potential in the new trend for wall-to-wall carpeting. Seizing the opportunity, they developed a range of felt underlay for carpet tiles and made their first move into the flooring market. This paved the way for the success of their next product, Duralay: the world's first crumb rubber underlay. It's this enterprising spirit that has formed the heart of Interfloor ever since.

## 1789

Durie & Miller establish a small hand-weaving company in Blairgowrie, near Dundee.

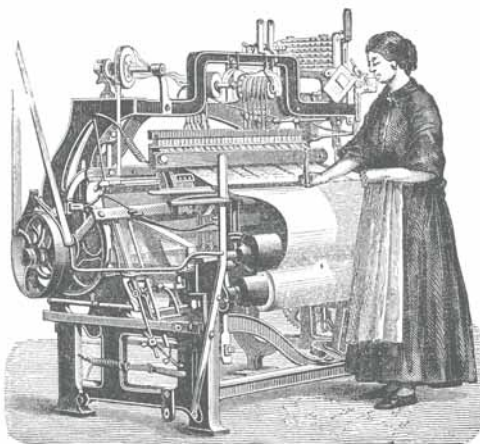

## Leading the way for comfort

Tredaire also comes from a tradition of excellence. Originally based in Scotland, Tredaire made its debut at the 1958 Carpet Fair in Earl's Court to critical acclaim and has grown to become a byword for outstanding underfoot feel. Since then, both companies continued to push the envelope of underlay design, refining them into the products we see today.

Both brands were united in 2002 to create Interfloor, representing the best of British manufacturing, and to this day, we're continuing to build on our legacy of quality. We've brought together the Gripperods and Stikatak brands to provide fitters with everything they need for installation. We've developed underlays that use recycled materials to support sustainable living and we've been given awards in exporting by providing our products to over 70 different countries. Interfloor's heritage begins in 1789 but continues in the present day - we're making history every time we innovate.



## 1969

Super Duralay achieves a 75% share of the rubber underlay market.



## 1952

The world's first crumb rubber underlay, Super Duralay, is developed and patented.

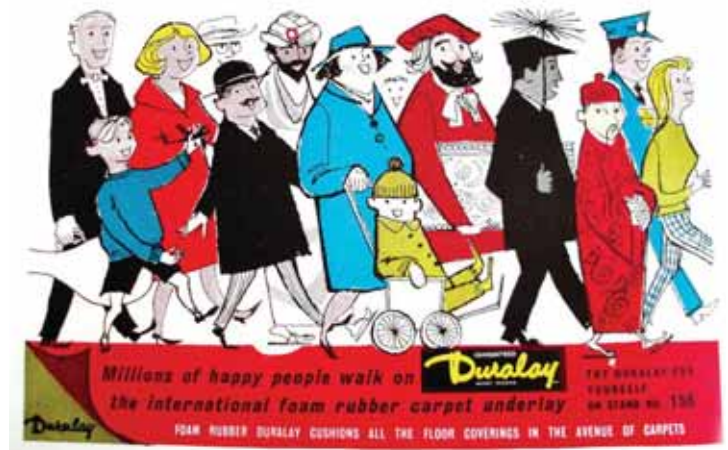



**2015**  
Interfloor acquired by Victoria plc, a global manufacturer, supplier and distributor of design-led flooring.



**1998**  
Gripperrods Ltd acquired by Gates Rubber Co. Ltd.



**2021**  
We launch our 'greenest' underlay to date: renu, and our specialist acoustic solutions range under our SONIXX® brand.



**2002**  
Interfloor is created following the merger of the Duralay and Tredaire brands.



**2022**  
We add our Tredaire Premier range.



**2024**  
One giant leap for comfort.



Meet the Tredaire-nauts, our brand-new characters crafted to share the Tredaire story of bringing unparalleled comfort and luxury to homes across the universe. Marking the start of our biggest campaign yet, blending TV, radio, and digital ads to educate consumers about the unmistakable feeling that comes with a quality Tredaire underlay beneath their feet.



# WHY CHOOSE OUR UNDERLAY?

Interfloor are internationally recognised specialists in underlay manufacture and the popularity of our products is down to our belief in providing quality solutions that stand the test of time.



## The best for comfort

Our PU foam and sponge rubber underlays offer a luxurious underfoot feel and contain air pockets for extra cushioning.



## Carpets look better for longer

The support offered by our underlays help to prevent pile flattening so that carpets are kept looking as good as new.



## Extends lifetime of flooring

Underlay acts as a shock absorber so that carpets suffer less wear. New underlay can extend the lifespan of a carpet by up to 50%.



## Sustainably designed

Many of our underlays are manufactured using recycled materials. Our newest underlay, renu®, is made of 98% reclaimed materials and is 100% recyclable.



## Increases heat retention

Our high tog underlays help to keep interiors warm and inviting. The increased insulation they offer can help to reduce energy usage and heating bills.



## Minimises in-room noise

Choosing the right underlay can reduce noise up to 30% and provide a better quality of life indoors. We also offer specialist acoustic solutions for contract flooring.



## Improves hygiene

With underlay, carpets are easier to clean because it prevents the pile ingraining dirt into the floor. This makes it a far more hygienic option.



# PROUD TO BE MADE IN THE UK

Through our in-house manufacturing facilities in Lancashire, we are able to maintain strict quality control and provide world-class underlays with consistent reliability.

This also means we fulfil orders quickly without the delays caused by a long supply chain. At any one time, our warehouses are stocked with thousands of rolls of underlay to ensure we always have the right products to meet your needs.



## PROUD WINNERS OF THE FOLLOWING AWARDS



AWARD WINNER  
INNOVATIONS IN  
EXPORTING



BEST UNDERLAY  
MANUFACTURER



2025  
FLOORING  
INNOVATION AWARD  
GOLD WINNER



AWARD WINNER  
EXPORT EXCELLENCE  
IN MEGA

# interfloor

## QUALITY UNDERLAY THAT YOU CAN TRUST

We manufacture the leading brands in the underlay market, **Tredaire**® and **Duralay**®, as well as our extensive accessories ranges, **Gripperrods**® and **Stikatak**®.

Recognised by customers as brands of quality and with over 70 years of expertise, they are trusted by users across the world.



Specialist Acoustic  
Solutions

In a multi-occupancy space, impact and airborne sound can permeate through to other rooms and floors. Harnessing Interfloor's technical expertise, the Sonixx® range of products gives specifiers easy-install solutions that incorporate noise reduction directly into the floor at construction stage.

In modern architecture, the wellbeing of the end user is a crucial factor, and the key to providing a better standard of living comes from the design of the building itself. Sonixx® was developed to deliver the technical high-performance underlayment for industry, implementing sound insulation requirements into the fabric of each build.



## Creating a strong underlay foundation

Our range of tapes and adhesives provides strength and resilience to underlay installations for a long-lasting finish. This collection of products offers everything for the professional fitter with solutions that match all flooring types.



## Gripperrods®

Gripperrods® offers quality, consistency and reliability. Our highly regarded products include metal profiles, carpet gripper and heat seaming tapes as well as single and double-sided tapes. Gripperrods® products ensure a high-quality floor fitting and provide the extra finishing touches to ensure every installation looks its very best.

## Premier metals

Gripperrods Premier Floor Edgings provide an exceptional finish to premium flooring installations.

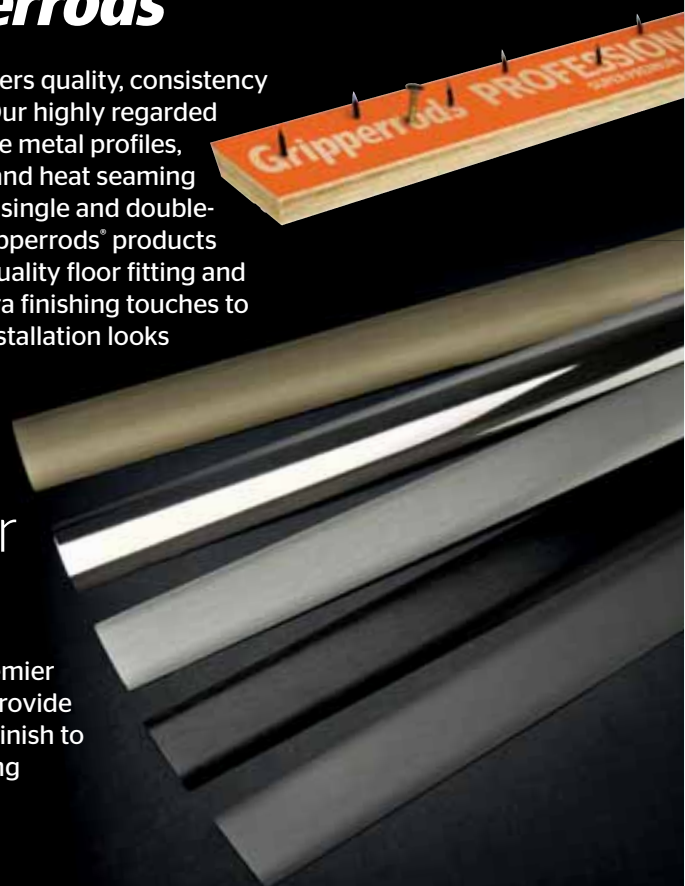

# tredaire®

carpet underlay

OUR BRANDS

## Feels like nothing on earth



Tredaire, the UK's premier choice for premium underlay, comes in both PU and sponge rubber varieties, offering an out of this world experience with every step. This unparalleled comfort also provides excellent insulation against heat and sound. Additionally, our Tredaire PU underlays are environmentally friendly, made from 100% recycled foam.

# Duralay®

Underlay Experts Since 1952

## Technical excellence

Duralay® is known for its durability and is also the underlay of choice for specialist needs. Ultra-high density crumb rubber is perfect for long lasting carpet protection and supporting carpets in high traffic areas, such as hallways and staircases. Duralay's sponge rubber underlays are the best for underfloor heating and noise reduction under hard flooring.



# UNDERLAYS EXPLAINED

The variety of underlay types we offer represent just how many different scenarios a fitter can experience. Though underlay was traditionally confined to the average under-carpet domestic installation, today's consumer may be looking for an underlay for use with wood, laminate, LVT flooring or underfloor heating systems. There may be requirements for large-scale commercial interiors so knowing which underlays offer the most benefit is the best way to ensure the longevity of the flooring.

## PU foam underlay

PU foam stands for polyurethane foam. It provides exceptional insulation, impact noise reduction and comfort. The foam in this underlay springs back to its original shape under load and is also lightweight, making it easy to carry and fit. It excels in standard domestic spaces due to the exceptional underfoot comfort.



## Sponge rubber underlay

Sponge rubber underlays are the most traditional form of underlay and have remained a mainstay of the industry since the 1950s.

No other underlay feels like sponge rubber underfoot - it is extremely springy and comfortable to walk on, one of the main reasons for its popularity. It also has highly versatile applications. More flexible than PU foam, with excellent impact and airborne noise reduction, it can be used in a multitude of interior types. Sponge rubber underlay is also available in low tog varieties for use with underfloor heating systems.

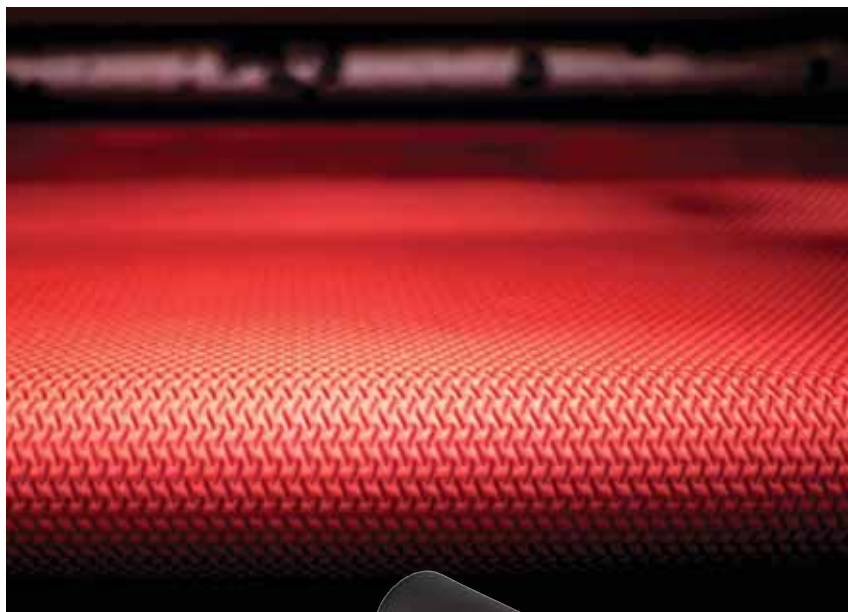

## Crumb rubber underlay

Crumb rubber underlays are exceptionally durable. They offer superb performance over their long lifespans with excellent impact and airborne noise reduction. While they don't offer the same level of comfort as a PU foam or sponge rubber underlay, their robust design provides effective protection in high-traffic and large areas.

It is the only type of underlay that offers 100% recovery under load.

## Crumb / Felt combination

The rubber base is made from recycled car tyres and natural rubber latex. The 'felt' base is made from either the polymer PES, containing recycled pre-consumer plastic or 100% recycled wool fibres.

The perfect choice for Wilton and Axminster style carpets. The felt backing means that carpets with stitched joins bed into the top felt layer and prevent wear along the join.



## IMO Compliance

Interfloor's materials pass the IMO's surface flammability, smoke and toxicity requirements for floor coverings and are deemed suitable for installations offshore and on seafaring vessels travelling in international waters. Materials which pass the IMO FTP tests also meet the requirements of the Maritime Equipment Directive (MED) before they can be affixed with the 'wheel mark' of compliance.



# BACKINGS EXPLAINED

The underlay backing provides important dimensional stability and increases its durability and lifespan. We provide a range of high-quality backings to suit different products and applications.



## Textron® Stitched Kraft Paper

Textron® creped kraft paper is longitudinally reinforced using 3.0 stitches per inch with a polyester weft for extra dimensional stability, giving the backing excellent load bearing and stress dissipation properties. It is resistant to soiling and is easy to cut and trim.



## Polyethylene with Reinforcing Mesh

The mesh used in this backing provides improved dimensional stability, making it more resistant to tearing. It is easy to cut and trim to fit.



## Woven Polypropylene

Used on our Crumb Rubber underlays, this exclusive backing provides superior dimensional stability. Its black colour and distinctive striping is used to ensure correct installation and also makes it easy to apply any necessary adhesives and spot gaps in coverage.



## Spunbonded Polyester

A non-woven scrim, spunbonded polyester offers good dimensional stability and resistance to tearing. It is easy to trim and cut to size.



## OUR GUARANTEE

We don't quote a number of years as a guarantee. Ours is even better: we guarantee that where fitted correctly, our underlays will last for the full serviceable lifetime of the new carpet installed at the same time.



# Out-of-this-world underlay comfort

Tredaire has become synonymous with luxurious underfoot comfort. Throughout our history, the brand has used polyethylene (PU) foam to create underlays that feel like nothing on earth!. The secret lies in the air pockets within PU foam, which help Tredaire products maintain their plush, new feel for longer. Offering a galaxy of options, Tredaire provides a range of comfortable underlays tailored to fit virtually any budget, ensuring every step is one giant leap for comfort.



## Cushioning with every step

Tredaire's luxury carpet underlays provide out of this world comfort to create spaces that feel luxurious and relaxing from the moment you step into the room. The extensive collection of underlays are designed to extend the life of carpets within a broad galaxy of spaces and applications.

## Carpet protection that lasts

In rooms with heavy furniture, a good quality underlay makes all the difference. Interfloor carpet underlays support the underside of carpet backings to prevent damage from pressure points and preserve the quality of the carpet for longer. An important and cost-effective investment that increases the longevity of the carpet.



Our PU underlay range is made from 100% recycled foam.

# Countdown to comfort

5

**Comfort and luxury  
you can feel**

Prepare for softer landings,  
living rooms, bedrooms...

4

**Keep that new carpet  
look for longer**

Your carpet will last for light years.

3

**Helps your carpet  
bounce back**

Gravity-defying underlay!

2

**Options for every  
room in the house**

We've got the universe covered.

1

**Made in the UK**

Reducing our impact  
on the environment.



**Feels like nothing on earth**

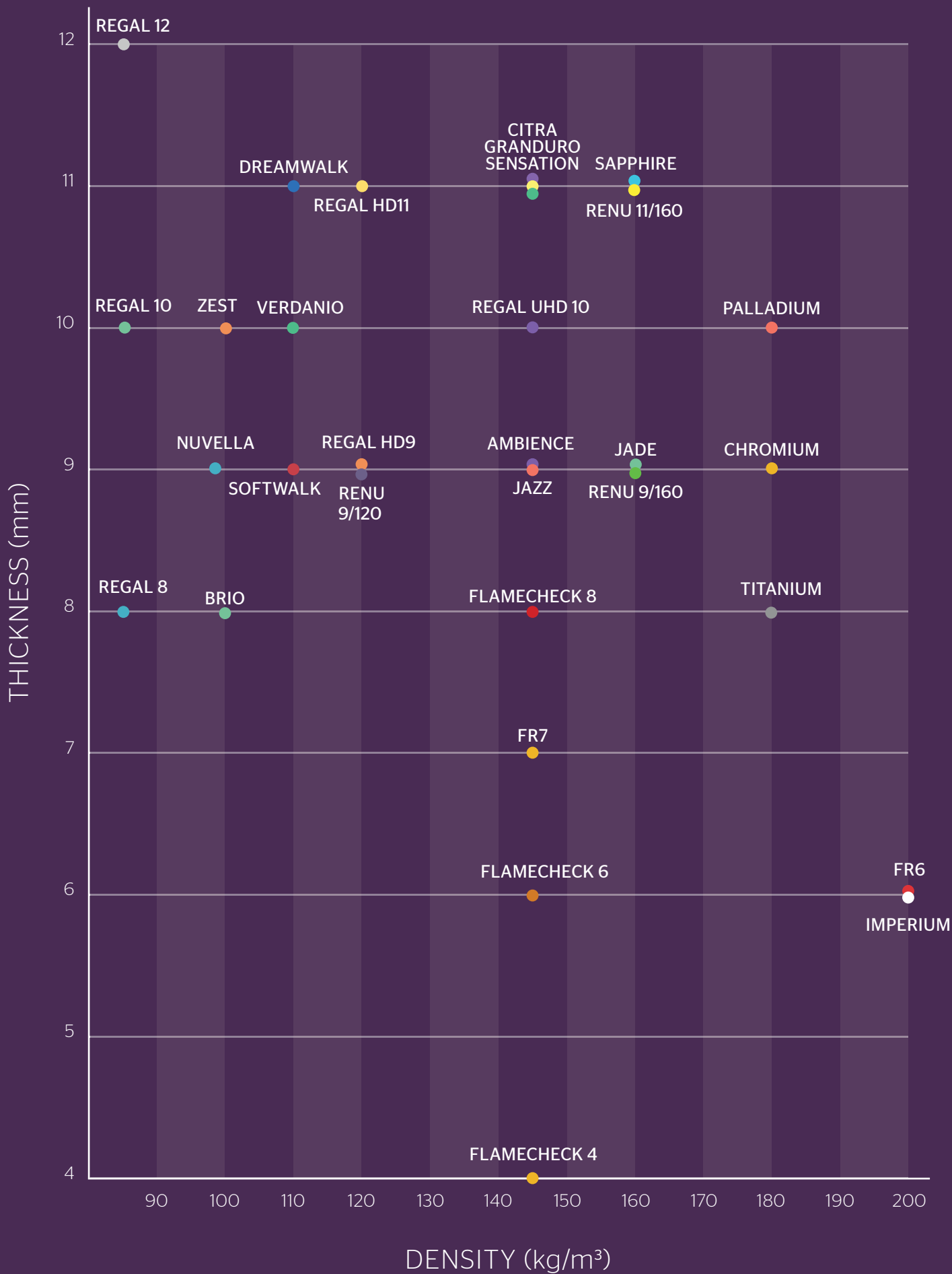

# tredaire | premier

Premium carpet underlay,  
with a difference you can feel

**When you think of luxury,  
think of Tredaire Premier.**

Our finest underlays, made with comfort  
in mind and quality you can trust.

The new and improved Tredaire Premier  
includes a high-spec Textron® backing  
with an eye-catching  
design. Not forgetting  
the layer of 100%  
recycled foam to add a  
wonderful, sumptuous  
feel like no other.

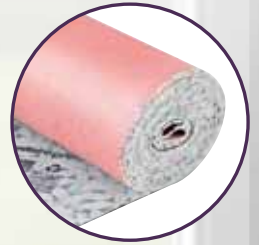

# the tredaire premier range



	Thickness (mm)	Density (Kg/m <sup>3</sup> )
Sensation	11	145.00
Dreamwalk	11	110.00
Palladium	10	180.00
Chromium	9	180.00
Ambience	9	145.00
Softwalk	9	110.00
Titanium	8	180.00
Imperium	6	200.00

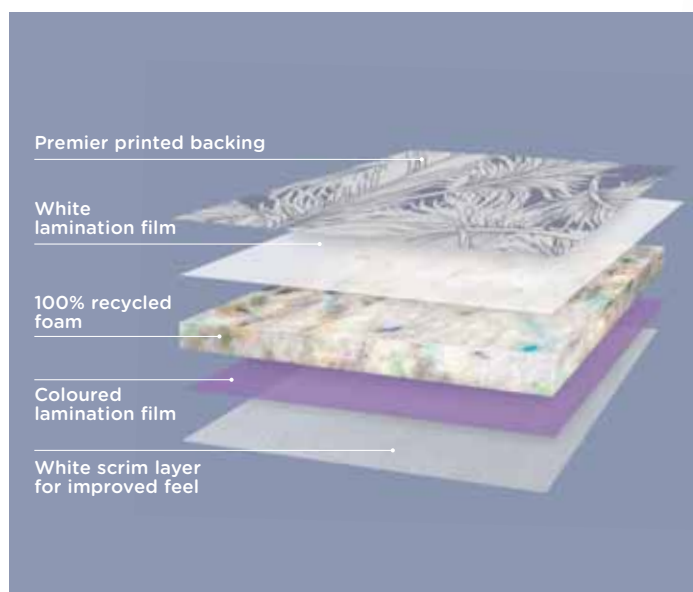

# great benefits for our stockists

Feature on our website and receive free point of sale.

All our point of sale is manufactured from sustainable, recycled sources and our print is on recycled paper and board.



DISCOVER MORE →  
Simply scan the QR code with your phone.



Become a Tredaire Premier Stockist today



Stockists of **tredaire premier** will be listed on our online stockist locator.

[www.interfloor.com](http://www.interfloor.com)



**AMBIENCE** TA AMBIENCE4 **tredaire** premier



THICKNESS	DENSITY	ROLL WEIGHT	ROLL AREA	HEAT INSULATION	SOUND REDUCTION
9.00 mm	145 kg/m <sup>3</sup>	19.7 kg	15.07 m <sup>2</sup>	2.37 Tog	39 dB

Ultra-high density underlay  
Textron® stitched kraft paper backing  
Stretch-fit  
100% recycled foam

**LUXURY USE**

Comfort	5 ★★★★★
Durability	5 ★★★★★
Warmth	5 ★★★★★
Impact Sound	5 ★★★★★
Airborne Sound	2 ★★
Underfloor Heating	Unsuitable

**BRIO** TABRIO3 **tredaire**



THICKNESS	DENSITY	ROLL WEIGHT	ROLL AREA	HEAT INSULATION	SOUND REDUCTION
8.00 mm	100 kg/m <sup>3</sup>	11.9 kg	15.07 m <sup>2</sup>	2.18 Tog	32 dB

High density underlay  
Upgraded twin-scrim design  
Spunbonded polyester backing  
Stretch-fit  
100% recycled foam

**GENERAL DOMESTIC USE**

Comfort	5 ★★★★★
Durability	4 ★★★★★
Warmth	5 ★★★★★
Impact Sound	4 ★★★★★
Airborne Sound	1 ★
Underfloor Heating	Unsuitable

**CHROMIUM** TACHROMIUM4 **tredaire** premier



THICKNESS	DENSITY	ROLL WEIGHT	ROLL AREA	HEAT INSULATION	SOUND REDUCTION
9.00 mm	180 kg/m <sup>3</sup>	25.8 kg	15.07 m <sup>2</sup>	2.26 Tog	42 dB

Premium high density underlay  
Textron® stitched kraft paper backing  
Stretch-fit  
100% recycled foam

**HEAVY CONTRACT USE**

Comfort	5 ★★★★★
Durability	5 ★★★★★
Warmth	5 ★★★★★
Impact Sound	6 ★★★★★★
Airborne Sound	3 ★★★
Underfloor Heating	Unsuitable

**CITRA** TACITRA2 **tredaire**



THICKNESS	DENSITY	ROLL WEIGHT	ROLL AREA	HEAT INSULATION	SOUND REDUCTION
11.00 mm	145 kg/m <sup>3</sup>	24.1 kg	15.07 m <sup>2</sup>	2.90Tog	43 dB

Ultra-high density underlay  
Great sound and heat insulation  
Upgraded twin-scrim design  
Spunbonded polyester backing  
Stretch-fit  
100% recycled foam

**LUXURY USE**

Comfort	6 ★★★★★★
Durability	5 ★★★★★
Warmth	6 ★★★★★★
Impact Sound	6 ★★★★★★
Airborne Sound	2 ★★
Underfloor Heating	Unsuitable

## Everyday heroes

All-round *Winners*  
to suit every budget

Zest, Brio, Jazz and Citra

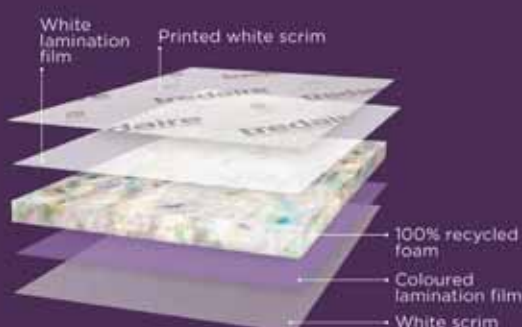

**MADE IN THE UK**

**DREAMWALK** TADREAMWALK4 **tredaire** premier



THICKNESS	DENSITY	ROLL WEIGHT	ROLL AREA	HEAT INSULATION	SOUND REDUCTION
11.00 mm	110 kg/m <sup>3</sup>	19.3 kg	15.07 m <sup>2</sup>	3.13 Tog	44 dB

High density underlay  
 Textron® stitched kraft paper backing  
 Great sound and heat insulation  
 Stretch-fit  
 100% recycled foam

LUXURY USE	
Comfort	6 ★★★★★★
Durability	5 ★★★★★
Warmth	6 ★★★★★★
Impact Sound	6 ★★★★★★
Airborne Sound	2 ★★
Underfloor Heating	Unsuitable

**FLAMECHECK 4** TAFLAMECHECK4 **tredaire**



THICKNESS	DENSITY	ROLL WEIGHT	ROLL AREA	HEAT INSULATION	SOUND REDUCTION
4.00 mm	145 kg/m <sup>3</sup>	9.30 kg	15.07 m <sup>2</sup>	1.02 Tog	26 dB

Ultra-high density underlay  
 Flame retardant carpet underlay  
 IMO certified, see page 41  
 Polyethylene/Spunbonded polyester  
 Double-stick and stretch-fit  
 100% recycled foam

HEAVY CONTRACT USE	
Comfort	3 ★★★
Durability	5 ★★★★★
Warmth	3 ★★★
Impact Sound	4 ★★★★★
Airborne Sound	2 ★★
Underfloor Heating	Unsuitable



**FLAMECHECK 6** TAFLAMECHECK6 **tredaire**



THICKNESS	DENSITY	ROLL WEIGHT	ROLL AREA	HEAT INSULATION	SOUND REDUCTION
6.00 mm	145 kg/m <sup>3</sup>	14.0 kg	15.07 m <sup>2</sup>	1.58Tog	30dB

Ultra-high density underlay  
 Flame retardant carpet underlay  
 IMO certified, see page 41  
 Polyethylene/Spunbonded polyester  
 Double-stick and stretch-fit  
 100% recycled foam

HEAVY CONTRACT USE	
Comfort	4 ★★★★★
Durability	5 ★★★★★
Warmth	4 ★★★★★
Impact Sound	4 ★★★★★
Airborne Sound	2 ★★
Underfloor Heating	Unsuitable



**FLAMECHECK 8** TAFLAMECHECK8 **tredaire**



THICKNESS	DENSITY	ROLL WEIGHT	ROLL AREA	HEAT INSULATION	SOUND REDUCTION
8.00 mm	145 kg/m <sup>3</sup>	18.3 kg	15.07 m <sup>2</sup>	1.99Tog	34dB

Ultra-high density underlay  
 Flame retardant carpet underlay  
 IMO certified, see page 41  
 Polyethylene / Flame retardant 85gsm crepe paper  
 Double-stick and stretch-fit  
 100% recycled foam

HEAVY CONTRACT USE	
Comfort	4 ★★★★★
Durability	5 ★★★★★
Warmth	4 ★★★★★
Impact Sound	4 ★★★★★
Airborne Sound	2 ★★
Underfloor Heating	Unsuitable



**FR6** TAFR6 **tredaire**



THICKNESS	DENSITY	ROLL WEIGHT	ROLL AREA	HEAT INSULATION	SOUND REDUCTION
6.00 mm	200 kg/m <sup>3</sup>	18.8 kg	15.07 m <sup>2</sup>	1.68 Tog	35 dB

Premium high density plus underlay  
 Flame retardant  
 Double-stick and stretch-fit  
 100% recycled foam

HEAVY CONTRACT USE	
Comfort	4 ★★★★★
Durability	5 ★★★★★
Warmth	4 ★★★★★
Impact Sound	4 ★★★★★
Airborne Sound	2 ★★
Underfloor Heating	Unsuitable

Note: All FR Products achieve a minimum of Cl-s1 when tested to EN13 501

**FR7** TAFR7 **tredaire**



THICKNESS	DENSITY	ROLL WEIGHT	ROLL AREA	HEAT INSULATION	SOUND REDUCTION
7.00 mm	145 kg/m <sup>3</sup>	15.3 kg	15.07 m <sup>2</sup>	1.99 Tog	34 dB

Ultra high density underlay  
Flame retardant  
Double-stick and stretch-fit  
100% recycled foam

**HEAVY CONTRACT USE**

Comfort	4 ★★★★★
Durability	5 ★★★★★★
Warmth	4 ★★★★★
Impact Sound	4 ★★★★★
Airborne Sound	2 ★★
Underfloor Heating	Unsuitable

Note: All FR Products achieve a minimum of Cfl-s1 when tested to EN13 501

**GRANDURO** TAGRANDURO **tredaire**



THICKNESS	DENSITY	ROLL WEIGHT	ROLL AREA	HEAT INSULATION	SOUND REDUCTION
11.00 mm	145 kg/m <sup>3</sup>	24.0 kg	15.07 m <sup>2</sup>	2.90 Tog	43 dB

Ultra-high density underlay  
Spunbonded polyester backing  
Great sound and great heat insulation  
Stretch-fit  
100% recycled foam

**LUXURY USE**

Comfort	6 ★★★★★★
Durability	5 ★★★★★★
Warmth	6 ★★★★★★
Impact Sound	6 ★★★★★★
Airborne Sound	2 ★★
Underfloor Heating	Unsuitable

**IMPERIUM** TAIMPERIUM4 **tredaire premier**



THICKNESS	DENSITY	ROLL WEIGHT	ROLL AREA	HEAT INSULATION	SOUND REDUCTION
6.00 mm	200 kg/m <sup>3</sup>	19.65 kg	15.07 m <sup>2</sup>	1.68 Tog	35 dB

Premium high-density underlay  
New Premier backing  
Combination film/scrim facing  
Great sound insulation  
Stretch-fit  
100% recycled foam

**LUXURY USE**

Comfort	6 ★★★★★★
Durability	5 ★★★★★★
Warmth	6 ★★★★★★
Impact Sound	6 ★★★★★★
Airborne Sound	2 ★★
Underfloor Heating	Unsuitable

**JADE** TAJADE2 **tredaire**



THICKNESS	DENSITY	ROLL WEIGHT	ROLL AREA	HEAT INSULATION	SOUND REDUCTION
9.00 mm	160 kg/m <sup>3</sup>	21.72 kg	15.07 m <sup>2</sup>	2.40 Tog	39dB

Ultra high density plus  
Film & mesh backing  
Stretch-fit  
100% recycled foam

**LUXURY USE**

Comfort	5 ★★★★★★
Durability	5 ★★★★★★
Warmth	5 ★★★★★★
Impact Sound	5 ★★★★★★
Airborne Sound	2 ★★
Underfloor Heating	Unsuitable

**JAZZ** TAJAZZ2 **tredaire**



THICKNESS	DENSITY	ROLL WEIGHT	ROLL AREA	HEAT INSULATION	SOUND REDUCTION
9.00 mm	145 kg/m <sup>3</sup>	19.7 kg	15.07 m <sup>2</sup>	2.37 Tog	39 dB

Ultra-high density underlay  
Upgraded twin-scrim design  
Spunbonded polyester backing  
Stretch-fit  
100% recycled foam

**LUXURY USE**

Comfort	5 ★★★★★★
Durability	5 ★★★★★★
Warmth	5 ★★★★★★
Impact Sound	5 ★★★★★★
Airborne Sound	2 ★★
Underfloor Heating	Unsuitable

**NUVELLA**

TANUVELLA **tredaire**



THICKNESS	DENSITY	ROLL WEIGHT	ROLL AREA	HEAT INSULATION	SOUND REDUCTION
9.00 mm	98 kg/m <sup>3</sup>	13.3 kg	15.07 m <sup>2</sup>	2.4 Tog	35 dB

High density underlay  
Spunbonded polyester backing  
Stretch-fit  
100% recycled foam

LUXURY USE

Comfort	5 ★★★★★
Durability	4 ★★★★★
Warmth	5 ★★★★★
Impact Sound	4 ★★★★★
Airborne Sound	2 ★★
Underfloor Heating	Unsuitable

**PALLADIUM**

TAPALLADIUM4 **tredaire premier**



THICKNESS	DENSITY	ROLL WEIGHT	ROLL AREA	HEAT INSULATION	SOUND REDUCTION
10.00 mm	180 kg/m <sup>3</sup>	28 kg	15.07 m <sup>2</sup>	2.59 Tog	43 dB

Premium high-density underlay  
Textron® stitched kraft paper backing  
Spunbonded polyester facing  
Great sound insulation  
Stretch-fit  
100% recycled foam

HEAVY CONTRACT USE

Comfort	5 ★★★★★
Durability	5 ★★★★★
Warmth	6 ★★★★★★
Impact Sound	6 ★★★★★★
Airborne Sound	3 ★★★
Underfloor Heating	Unsuitable

**REGAL 8**

TAREGAL8



THICKNESS	DENSITY	ROLL WEIGHT	ROLL AREA	HEAT INSULATION	SOUND REDUCTION
8.00 mm	85 kg/m <sup>3</sup>	11 kg	15.07 m <sup>2</sup>	2.32 Tog	34 dB

Medium density underlay  
Printed spunbonded polyester backing  
Stretch-fit  
100% recycled foam

GENERAL DOMESTIC USE

Comfort	4 ★★★★★
Durability	4 ★★★★★
Warmth	6 ★★★★★★
Impact Sound	4 ★★★★★
Airborne Sound	1 ★
Underfloor Heating	Unsuitable

**REGAL 10**

TAREGAL10



THICKNESS	DENSITY	ROLL WEIGHT	ROLL AREA	HEAT INSULATION	SOUND REDUCTION
10.00 mm	85 kg/m <sup>3</sup>	13.5 kg	15.07 m <sup>2</sup>	2.81 Tog	37 dB

Medium density underlay  
Printed spunbonded polyester backing  
Stretch-fit  
100% recycled foam

GENERAL DOMESTIC USE

Comfort	5 ★★★★★
Durability	4 ★★★★★
Warmth	6 ★★★★★★
Impact Sound	5 ★★★★★
Airborne Sound	2 ★★
Underfloor Heating	Unsuitable

**REGAL 12**

TAREGAL12



THICKNESS	DENSITY	ROLL WEIGHT	ROLL AREA	HEAT INSULATION	SOUND REDUCTION
12.00 mm	85 kg/m <sup>3</sup>	15.9 kg	15.07 m <sup>2</sup>	3.10 Tog	45 dB

Medium density underlay  
Printed spunbonded polyester backing  
Stretch-fit  
100% recycled foam

LUXURY USE

Comfort	6 ★★★★★★
Durability	4 ★★★★★
Warmth	6 ★★★★★★
Impact Sound	6 ★★★★★★
Airborne Sound	2 ★★
Underfloor Heating	Unsuitable

## REGAL HD 9

TAREGALHD9



THICKNESS	DENSITY	ROLL WEIGHT	ROLL AREA	HEAT INSULATION	SOUND REDUCTION
9.00 mm	120 kg/m <sup>3</sup>	17.20 kg	15.07 m <sup>2</sup>	2.80 Tog	41 dB

High density  
Printed spunbonded polyester backing  
Stretch-fit  
100% recycled foam

LUXURY USE

Comfort	5 ★★★★★
Durability	4 ★★★★★
Warmth	6 ★★★★★
Impact Sound	6 ★★★★★
Airborne Sound	2 ★★
Underfloor Heating	Unsuitable

## REGAL HD 11

TAREGALHD11



THICKNESS	DENSITY	ROLL WEIGHT	ROLL AREA	HEAT INSULATION	SOUND REDUCTION
11.00 mm	120 kg/m <sup>3</sup>	20.80 kg	15.07 m <sup>2</sup>	3.50 Tog	45dB

High density  
Printed spunbonded polyester backing  
Stretch-fit  
100% recycled foam

LUXURY USE

Comfort	6 ★★★★★
Durability	5 ★★★★★
Warmth	6 ★★★★★
Impact Sound	6 ★★★★★
Airborne Sound	2 ★★
Underfloor Heating	Unsuitable

## REGAL UHD 10

TAREGALHD10



THICKNESS	DENSITY	ROLL WEIGHT	ROLL AREA	HEAT INSULATION	SOUND REDUCTION
10.00 mm	145 kg/m <sup>3</sup>	22.4 kg	15.07 m <sup>2</sup>	2.6 Tog	39 dB

Ultra High density  
Printed spunbonded polyester backing  
Stretch-fit  
100% recycled foam

GENERAL DOMESTIC USE

Comfort	5 ★★★★★
Durability	5 ★★★★★
Warmth	6 ★★★★★
Impact Sound	6 ★★★★★
Airborne Sound	2 ★★
Underfloor Heating	Unsuitable

## RENU 9/120

TARENU9120 **tredaire**



THICKNESS	DENSITY	ROLL WEIGHT	ROLL AREA	HEAT INSULATION	SOUND REDUCTION
9.00 mm	120 kg/m <sup>3</sup>	17.6 kg	15.07 m <sup>2</sup>	2.06 Tog	44 dB

LUXURY USE

**renu**  
sustainable recycled underlay

High density  
Sustainable recycled underlay  
100% recycled Textron® stitched kraft paper backing  
Printed with vegetable based inks  
100% recycled post-consumer foam  
Carbon-negative bio-based film  
Flame retardant carpet underlay

Comfort	5 ★★★★★
Durability	5 ★★★★★
Warmth	5 ★★★★★
Impact Sound	5 ★★★★★
Airborne Sound	2 ★★
Underfloor Heating	Unsuitable

See page 28 for more info.



**RENU 9/160**

TARENU9160 **tredaire**

THICKNESS	DENSITY	ROLL WEIGHT	ROLL AREA	HEAT INSULATION	SOUND REDUCTION
9.00 mm	160 kg/m <sup>3</sup>	23.0 kg	15.07 m <sup>2</sup>	2.54 Tog	41 dB



LUXURY USE

Comfort	5 ★★★★★
Durability	5 ★★★★★
Warmth	5 ★★★★★
Impact Sound	5 ★★★★★
Airborne Sound	2 ★★
Underfloor Heating	Unsuitable

**renu**  
sustainable recycled underlay

- Ultra high density plus
- Flame retardant carpet underlay
- Sustainable recycled underlay
- 100% recycled Textron® stitched kraft paper backing
- Printed with vegetable based inks
- 100% recycled post-consumer foam
- Carbon-negative bio-based film

See page 28 for more info.



**RENU 11/160**

TARENU11160 **tredair**

THICKNESS	DENSITY	ROLL WEIGHT	ROLL AREA	HEAT INSULATION	SOUND REDUCTION
11.00 mm	160 kg/m <sup>3</sup>	27.86 kg	15.07 m <sup>2</sup>	3.05 Tog	46 dB



LUXURY USE

Comfort	6 ★★★★★★
Durability	5 ★★★★★
Warmth	5 ★★★★★
Impact Sound	5 ★★★★★
Airborne Sound	2 ★★
Underfloor Heating	Unsuitable

**renu**  
sustainable recycled underlay

- Ultra high density plus
- Sustainable recycled underlay
- 100% recycled Textron® stitched kraft paper backing
- Printed with vegetable based inks
- 100% recycled post-consumer foam
- Carbon-negative bio-based film
- Flame retardant carpet underlay

See page 28 for more info.



**SAPPHIRE**

TASAPPHIRE2 **tredaire**

THICKNESS	DENSITY	ROLL WEIGHT	ROLL AREA	HEAT INSULATION	SOUND REDUCTION
11.00 mm	160 kg/m <sup>3</sup>	26.33 kg	15.07 m <sup>2</sup>	2.68 Tog	41dB



LUXURY USE

Comfort	6 ★★★★★
Durability	5 ★★★★★
Warmth	6 ★★★★★
Impact Sound	6 ★★★★★
Airborne Sound	2 ★★
Underfloor Heating	Unsuitable

- Ultra high density plus
- Film & mesh backing
- Stretch-Fit
- 100% recycled foam

**SENSATION** TASENSATION4 **tredaire** premier



THICKNESS	DENSITY	ROLL WEIGHT	ROLL AREA	HEAT INSULATION	SOUND REDUCTION
11.00 mm	145 kg/m <sup>3</sup>	24.0 kg	15.07 m <sup>2</sup>	2.89 Tog	43 dB

Ultra high density underlay  
Textron® stitched kraft paper backing  
Great sound insulation  
Stretch-fit  
100% recycled foam

LUXURY USE

Comfort	6 ★★★★★★
Durability	5 ★★★★★
Warmth	6 ★★★★★★
Impact Sound	6 ★★★★★★
Airborne Sound	2 ★★
Underfloor Heating	Unsuitable

**SOFTWALK** TASOFTWALK4 **tredaire** premier



THICKNESS	DENSITY	ROLL WEIGHT	ROLL AREA	HEAT INSULATION	SOUND REDUCTION
9.00 mm	110 kg/m <sup>3</sup>	16.0 kg	15.07 m <sup>2</sup>	2.69 Tog	41 dB

High density underlay  
Flame retardant carpet underlay  
Textron® stitched kraft paper backing  
Stretch-fit  
100% recycled foam  
Flame retardant

LUXURY USE

Comfort	5 ★★★★★
Durability	4 ★★★★★
Warmth	6 ★★★★★★
Impact Sound	6 ★★★★★★
Airborne Sound	2 ★★
Underfloor Heating	Unsuitable

Note: All FR Products achieve a minimum of Cfl-s1 when tested to EN13 501

**TITANIUM** TATITANIUM3 **tredaire** premier



THICKNESS	DENSITY	ROLL WEIGHT	ROLL AREA	HEAT INSULATION	SOUND REDUCTION
8.00 mm	180 kg/m <sup>3</sup>	22.5 kg	15.07 m <sup>2</sup>	2.22 Tog	39 dB

Premium high density underlay  
Film & mesh backing  
Double-stick\* and stretch-fit  
100% recycled foam

HEAVY CONTRACT USE

For areas up to 30m<sup>2</sup>

Comfort	5 ★★★★★
Durability	5 ★★★★★
Warmth	5 ★★★★★
Impact Sound	5 ★★★★★
Airborne Sound	3 ★★★
Underfloor Heating	Unsuitable

**VERDANIO** TAVERDANIO **tredaire**



THICKNESS	DENSITY	ROLL WEIGHT	ROLL AREA	HEAT INSULATION	SOUND REDUCTION
10.00 mm	110 kg/m <sup>3</sup>	16.6 kg	15.07 m <sup>2</sup>	2.70 Tog	41 dB

High density underlay  
Spunbonded polyester backing  
Stretch-fit  
100% recycled foam

LUXURY USE

Comfort	6 ★★★★★★
Durability	5 ★★★★★
Warmth	6 ★★★★★★
Impact Sound	6 ★★★★★★
Airborne Sound	2 ★★
Underfloor Heating	Unsuitable

**ZEST** TAZEST3 **tredaire**



THICKNESS	DENSITY	ROLL WEIGHT	ROLL AREA	HEAT INSULATION	SOUND REDUCTION
10.00 mm	100 kg/m <sup>3</sup>	14.9 kg	15.07 m <sup>2</sup>	2.64 Tog	39 dB

High density underlay  
Spunbonded polyester backing  
Stretch-fit  
Upgraded twin-scrim design  
100% recycled foam

LUXURY USE

Comfort	6 ★★★★★★
Durability	4 ★★★★★
Warmth	6 ★★★★★★
Impact Sound	5 ★★★★★
Airborne Sound	2 ★★
Underfloor Heating	Unsuitable

# renu<sup>®</sup>

sustainable recycled underlay



## MADE FROM RECYCLED MATERIALS AND 100% RECYCLABLE.

renu<sup>®</sup> is different. A luxury underlay that is ethically sourced and seriously good for the planet.

At the end of its life, the renu can be collected and reused to create new underlay. It's what makes it so special.



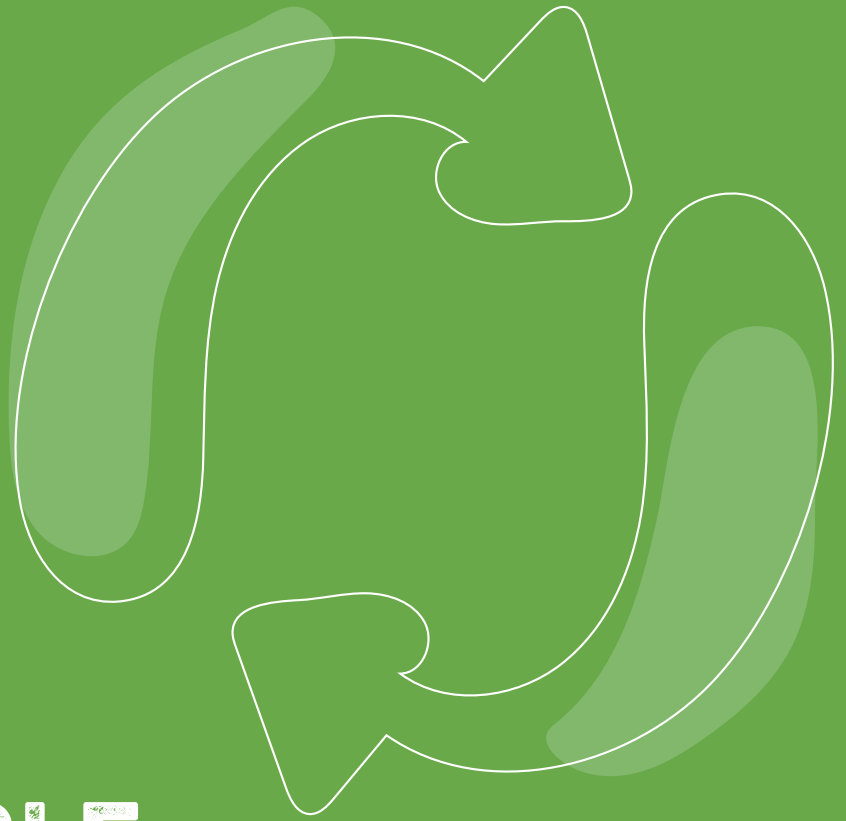

# SUSTAINABLE RECYCLED UNDERLAY

**renu<sup>®</sup> is the most ethically sourced and recyclable underlay we've ever made.**

It is made from 98% recycled materials, whilst also being 100% recyclable.

It's what we make renu<sup>®</sup> from that makes it so special! To make the bouncy bit in the middle, we steam clean, then bind together, the foam reclaimed from recycled soft furnishings. This gives that great underfoot comfort and insulation.

To give added resilience the foam is sandwiched between our 100% recycled Textron<sup>®</sup> paper backing and a layer of film.

The film layer is made from a responsibly produced, carbon-negative bio-based film that's made of sugar cane. We use this same recyclable bio-based film or an alternative 100% recycled plastic for the packaging, always striving to use the most environmentally friendly option possible.



## GREAT BENEFITS FOR OUR STOCKISTS

Feature on our website and receive free point of sale. All our point of sale is manufactured from sustainable, recycled sources and our print is on recycled paper and board.



### Stockist Locator

Become a renu® stockist and feature in our on-line Stockist Locator.



## WE ASKED CONSUMERS...

**88% OF HOMEOWNERS** would choose a recycled or recyclable carpet underlay over one that isn't.

**91% OF HOMEOWNERS** think it is important that a product is recyclable.

**84% OF HOMEOWNERS** are more likely to choose a product over another brand if they know what it is recycled from.

Survey commissioned by Interfloor in Nov' 2020

renu® range

tredaire

RENU 9/120		TARENU9120
ROLL AREA	HEAT INSULATION	SOUND REDUCTION
15.07 m <sup>2</sup>	2.06Tog	44dB
THICKNESS	DENSITY	ROLL WEIGHT
9.00 mm	120 kg/m <sup>3</sup>	17.6 KG

LUXURY USE

RENU 9/160		TARENU9160
ROLL AREA	HEAT INSULATION	SOUND REDUCTION
15.07 m <sup>2</sup>	2.54Tog	41dB
THICKNESS	DENSITY	ROLL WEIGHT
9.00 mm	160 kg/m <sup>3</sup>	23 kg

LUXURY USE

RENU 11/160		TARENU1160
ROLL AREA	HEAT INSULATION	SOUND REDUCTION
15.07 m <sup>2</sup>	3.05Tog	46dB
THICKNESS	DENSITY	ROLL WEIGHT
11.00 mm	160 kg/m <sup>3</sup>	27.86 KG

LUXURY USE

Made from 98% recycled materials whilst also being 100% recyclable.

Made using 100% post-consumer recycled foam.

Facing film made from sustainably sourced sugar cane.

100% recycled and unbleached Textron® paper backing printed using vegetable based inks.

When renu® reaches the end of its life it can be collected and used to make new rolls of renu®.

DISCOVER MORE



RENU® - PLANET FRIENDLY & RECYCLED UNDERLAY

# SPONGE RUBBER CARPET UNDERLAYS

Tredaire® and Duralay® sponge rubber underlays are the most traditional form of underlay. They have been around since the 1950s for very good reasons. They are **extremely comfortable** and are exceptionally **good at minimising both impact sound and airborne sound between rooms**. They are incredibly flexible and cover more applications than any other underlay type.

Finding the right underlay for your project is a matter of balancing thickness and density.

This chart allows you to compare these specifications across our sponge rubber range.

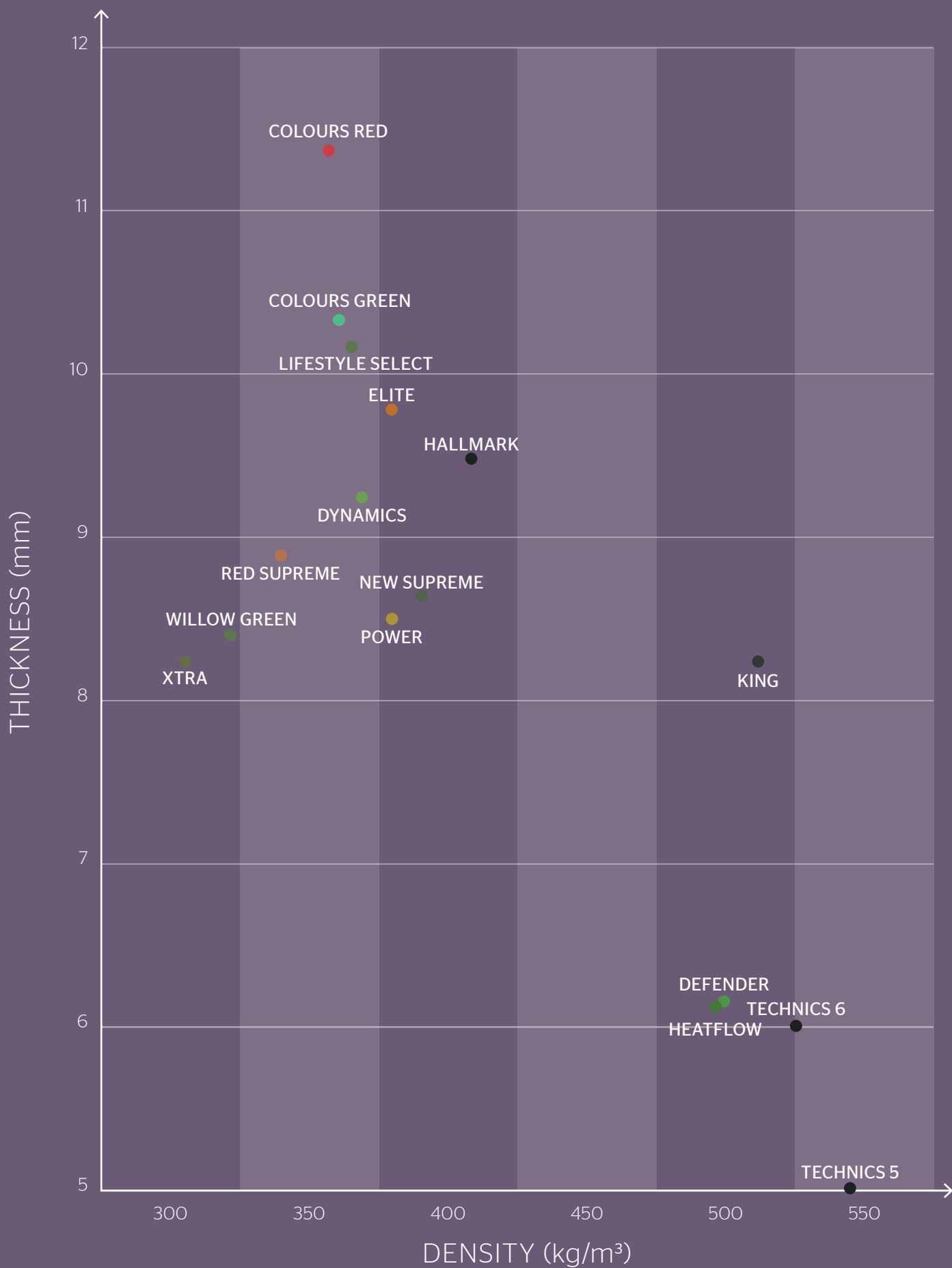

**COLOURS GREEN** TACOLGREEN **tredaire**

THICKNESS	DENSITY	ROLL WEIGHT	ROLL AREA	HEAT INSULATION	SOUND REDUCTION
10.30 mm	362 kg/m <sup>3</sup>	40.8 kg	10.96 m <sup>2</sup>	1.47 Tog	44 dB



**LUXURY USE**

Premium rubber compound  
Fantastic comfort  
Textron® stitched kraft paper backing  
Stretch-fit

Comfort	6 ★★★★★★
Durability	3 ★★★
Warmth	3 ★★★
Impact Sound	6 ★★★★★★
Airborne Sound	5 ★★★★★
Underfloor Heating	1 ★

**COLOURS RED** TACOLRED **tredaire**

THICKNESS	DENSITY	ROLL WEIGHT	ROLL AREA	HEAT INSULATION	SOUND REDUCTION
11.40 mm	357 kg/m <sup>3</sup>	44.5 kg	10.96 m <sup>2</sup>	1.65 Tog	46 dB



**LUXURY USE**

Premium rubber compound  
Incredible comfort  
Textron® stitched kraft paper backing  
Stretch-fit

Comfort	6 ★★★★★★
Durability	4 ★★★★★
Warmth	4 ★★★★★
Impact Sound	6 ★★★★★★
Airborne Sound	6 ★★★★★★
Underfloor Heating	1 ★

**DEFENDER** TADDEF3 **tredaire**

THICKNESS	DENSITY	ROLL WEIGHT	ROLL AREA	HEAT INSULATION	SOUND REDUCTION
6.10 mm	495 kg/m <sup>3</sup>	45.5 kg	15.07 m <sup>2</sup>	0.80Tog	31 dB



**HEAVY CONTRACT USE**

Textron® stitched kraft paper backing  
Flame retardant carpet underlay  
Stretch-fit

Comfort	4 ★★★★★
Durability	5 ★★★★★
Warmth	2 ★★
Impact Sound	4 ★★★★★
Airborne Sound	4 ★★★★★
Underfloor Heating	6 ★★★★★★

**DYNAMICS** TADYNAMICS2 **tredaire**

THICKNESS	DENSITY	ROLL WEIGHT	ROLL AREA	HEAT INSULATION	SOUND REDUCTION
9.40 mm	368 kg/m <sup>3</sup>	37.9 kg	10.96 m <sup>2</sup>	1.30Tog	35 dB



**LUXURY USE**

Textron® stitched kraft paper backing  
Flame retardant carpet underlay  
Stretch-fit

Comfort	5 ★★★★★★
Durability	4 ★★★★★
Warmth	3 ★★★
Impact Sound	4 ★★★★★
Airborne Sound	4 ★★★★★
Underfloor Heating	3 ★★★

**ELITE** TAEELITE **tredaire**

THICKNESS	DENSITY	ROLL WEIGHT	ROLL AREA	HEAT INSULATION	SOUND REDUCTION
9.75 mm	379 kg/m <sup>3</sup>	40.5 kg	10.96 m <sup>2</sup>	1.5Tog	42 dB



**LUXURY USE**

Textron® stitched kraft paper backing  
Stretch-fit

Comfort	6 ★★★★★★
Durability	4 ★★★★★
Warmth	4 ★★★★★
Impact Sound	6 ★★★★★★
Airborne Sound	5 ★★★★★
Underfloor Heating	1 ★

Note: All FR Products achieve a minimum of Cfl-s1 when tested to EN13 501

**HALLMARK**

TAHK080013 **tredaire**



THICKNESS	DENSITY	ROLL WEIGHT	ROLL AREA	HEAT INSULATION	SOUND REDUCTION
9.50 mm	410 kg/m <sup>3</sup>	42.7 kg	10.96 m <sup>2</sup>	1.51Tog	42 dB



Textron® stitched kraft paper backing  
Stretch-fit

LUXURY USE

Comfort	5 ★★★★★
Durability	5 ★★★★★
Warmth	4 ★★★★★
Impact Sound	6 ★★★★★★
Airborne Sound	5 ★★★★★
Underfloor Heating	1 ★

**HEATFLOW CARPET**

TAHEATCARPET2 **Duralay**



THICKNESS	DENSITY	ROLL WEIGHT	ROLL AREA	HEAT INSULATION	SOUND REDUCTION
6.10 mm	495 kg/m <sup>3</sup>	30.2 kg	10.00 m <sup>2</sup>	0.75Tog	31 dB



Textron® stitched kraft paper backing  
Stretch-fit  
Suitable for underfloor heating

LUXURY USE

Comfort	4 ★★★★★
Durability	5 ★★★★★
Warmth	2 ★★
Impact Sound	4 ★★★★★
Airborne Sound	4 ★★★★★
Underfloor Heating	6 ★★★★★★

**KING**

TADK080013 **tredaire**



THICKNESS	DENSITY	ROLL WEIGHT	ROLL AREA	HEAT INSULATION	SOUND REDUCTION
8.30 mm	511 kg/m <sup>3</sup>	46.5kg	10.96 m <sup>2</sup>	0.80 Tog	42 dB



Textron® stitched kraft paper backing  
Stretch-fit  
Suitable for underfloor heating

LUXURY USE

Comfort	5 ★★★★★
Durability	6 ★★★★★★
Warmth	2 ★★
Impact Sound	6 ★★★★★★
Airborne Sound	6 ★★★★★★
Underfloor Heating	6 ★★★★★★

**LIFESTYLE SELECT**

TALSS08013 **tredaire**



THICKNESS	DENSITY	ROLL WEIGHT	ROLL AREA	HEAT INSULATION	SOUND REDUCTION
10.20 mm	365 kg/m <sup>3</sup>	40.9 kg	10.96 m <sup>2</sup>	1.51 Tog	37 dB



Spunbonded polyester backing  
Stretch-fit

LUXURY USE

Comfort	6 ★★★★★★
Durability	3 ★★★
Warmth	4 ★★★★★
Impact Sound	6 ★★★★★★
Airborne Sound	5 ★★★★★
Underfloor Heating	1 ★

**NEW SUPREME**

TANEWSUP **tredaire**

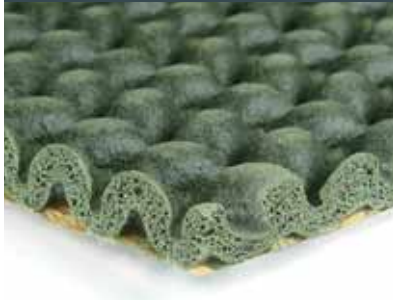

THICKNESS	DENSITY	ROLL WEIGHT	ROLL AREA	HEAT INSULATION	SOUND REDUCTION
8.75 mm	391 kg/m <sup>3</sup>	37.5 kg	10.96 m <sup>2</sup>	1.00 Tog	39dB



Textron® stitched kraft paper backing  
Stretch-fit

LUXURY USE

Comfort	5 ★★★★★
Durability	5 ★★★★★
Warmth	3 ★★★
Impact Sound	5 ★★★★★
Airborne Sound	4 ★★★★★
Underfloor Heating	5 ★★★★★

**POWER** TAPOWER3 **tredaire**

THICKNESS	DENSITY	ROLL WEIGHT	ROLL AREA	HEAT INSULATION	SOUND REDUCTION
8.60 mm	378 kg/m <sup>3</sup>	35.7 kg	10.96 m <sup>2</sup>	1.10 Tog	37 dB



**LUXURY USE**

Texttron® stitched kraft paper backing  
Stretch-fit

Comfort	5 ★★★★★
Durability	5 ★★★★★
Warmth	3 ★★★
Impact Sound	5 ★★★★★
Airborne Sound	4 ★★★★★
Underfloor Heating	4 ★★★★★

**RED SUPREME** TASH110013 **tredaire**

THICKNESS	DENSITY	ROLL WEIGHT	ROLL AREA	HEAT INSULATION	SOUND REDUCTION
8.90 mm	343 kg/m <sup>3</sup>	46 kg	15.07 m <sup>2</sup>	1.27 Tog	41 dB





**LUXURY USE**

Texttron® stitched kraft paper backing  
Stretch-fit

Comfort	5 ★★★★★
Durability	5 ★★★★★
Warmth	3 ★★★
Impact Sound	6 ★★★★★★
Airborne Sound	4 ★★★★★
Underfloor Heating	3 ★★★

**TECHNICS 5** TATECH5 **Duralay**

THICKNESS	DENSITY	ROLL WEIGHT	ROLL AREA	HEAT INSULATION	SOUND REDUCTION
5.00 mm	542 kg/m <sup>3</sup>	40.90 kg	15.07 m <sup>2</sup>	0.56 Tog	29 dB

**HEAVY CONTRACT USE**

Suitable for under carpet or wood and laminate flooring  
Double-stick, stretch fit & floating floor  
Texttron® stitched kraft paper backing  
Flame retardant carpet underlay

Comfort	3 ★★★
Durability	5 ★★★★★
Warmth	2 ★★
Impact Sound	4 ★★★★★
Airborne Sound	4 ★★★★★
Underfloor Heating	6 ★★★★★★

**TECHNICS 6** TATECH6 **Duralay**

THICKNESS	DENSITY	ROLL WEIGHT	ROLL AREA	HEAT INSULATION	SOUND REDUCTION
6.00 mm	525 kg/m <sup>3</sup>	47.5 kg	15.07 m <sup>2</sup>	0.66 Tog	34 dB



**HEAVY CONTRACT USE**

Perfect for high traffic areas & border-work  
Double-stick or stretch fit  
Texttron® stitched kraft paper backing  
Flame retardant carpet underlay

Comfort	4 ★★★★★
Durability	5 ★★★★★
Warmth	2 ★★
Impact Sound	4 ★★★★★
Airborne Sound	4 ★★★★★
Underfloor Heating	6 ★★★★★★

**WILLOW GREEN** TAWILLOW **tredaire**

THICKNESS	DENSITY	ROLL WEIGHT	ROLL AREA	HEAT INSULATION	SOUND REDUCTION
8.40 mm	323 kg/m <sup>3</sup>	40.8 kg	15.7 m <sup>2</sup>	1.1 Tog	32 dB



**GENERAL DOMESTIC USE**

Texttron® stitched kraft paper backing  
Stretch-fit

Comfort	5 ★★★★★
Durability	4 ★★★★★
Warmth	3 ★★★
Impact Sound	4 ★★★★★
Airborne Sound	4 ★★★★★
Underfloor Heating	4 ★★★★★

XTRA

TAXD110013

tredaire



THICKNESS	DENSITY	ROLL WEIGHT	ROLL AREA	HEAT INSULATION	SOUND REDUCTION
8.25 mm	308 kg/m <sup>3</sup>	40.9 kg	15.07 m <sup>2</sup>	1.51 Tog	35 dB



GENERAL DOMESTIC USE

Textron® stitched kraft paper backing  
Stretch-fit

Comfort	4 ★★★★★
Durability	4 ★★★★★
Warmth	4 ★★★★★
Impact Sound	4 ★★★★★
Airborne Sound	4 ★★★★★
Underfloor Heating	1 ★



## DURAFIT 500

TADURAFIT500 **Duralay**



THICKNESS	DENSITY	ROLL WEIGHT	ROLL AREA	HEAT INSULATION	SOUND REDUCTION
5.25 mm	400 kg/m <sup>3</sup>	31.60 kg	15.07 m <sup>2</sup>	0.83 Tog	26 dB

HEAVY  
CONTRACT USE

Flame  
Retardant

Comfort	3 ★★ ★
Durability	6 ★★ ★★ ★★
Warmth	2 ★★
Impact Sound	4 ★★ ★★
Airborne Sound	3 ★★ ★
Underfloor Heating	6 ★★ ★★ ★★

Contract quality carpet underlay  
 Flame retardant carpet underlay  
 Suitable for underfloor heating  
 Recycled crumb rubber from car tyres  
 Perfect for high traffic areas & border-work  
 Double-stick & stretch-fit  
 Polypropylene backing  
 Flame retardant carpet underlay

## DURAFIT 650

TADURAFIT650 **Duralay**



THICKNESS	DENSITY	ROLL WEIGHT	ROLL AREA	HEAT INSULATION	SOUND REDUCTION
6.50 mm	415 kg/m <sup>3</sup>	40.10 kg	15.07 m <sup>2</sup>	1.10 Tog	28 dB

HEAVY  
CONTRACT USE

Flame  
Retardant

Comfort	4 ★★ ★★
Durability	6 ★★ ★★ ★★
Warmth	3 ★★ ★
Impact Sound	4 ★★ ★★
Airborne Sound	4 ★★ ★★
Underfloor Heating	4 ★★ ★★

Contract quality carpet underlay  
 Flame retardant carpet underlay  
 Recycled crumb rubber from car tyres  
 Perfect for high traffic areas & border-work  
 Double-stick & stretch-fit  
 Polypropylene backing  
 Flame retardant carpet underlay

## The market leading double stick contract underlay!

Extremely durable, crumb rubber underlays are amazing at reducing impact and airborne noise and are the only type of underlay that can achieve 100% recovery from loading. Crumb rubber will extend the life of a carpet and improve insulation. Therefore being the number one choice for double-stick installations in hard wearing, high traffic and very large areas.

The high-performance rubber is environmentally friendly, manufactured from used car tyres, the basic raw material comes from 100% recycled rubber.

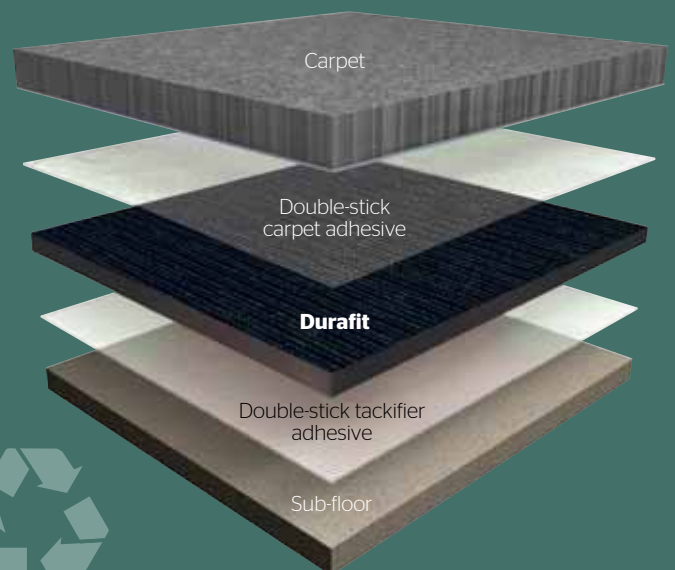

**SUPER MK3**

TASUPERMK3 **tredaire**

THICKNESS	DENSITY	ROLL WEIGHT	ROLL AREA	HEAT INSULATION	SOUND REDUCTION
6.75mm	359 kg/m <sup>3</sup>	36.50 kg	15.07 m <sup>2</sup>	1.15 Tog	26 dB



HEAVY CONTRACT USE

Comfort	4 ★★★★★
Durability	6 ★★★★★★
Warmth	3 ★★★
Impact Sound	4 ★★★★★
Airborne Sound	4 ★★★★★
Underfloor Heating	4 ★★★★★

Carpet protection from heavy wear  
 Recycled crumb rubber from car tyres  
 Crumb rubber carpet underlay  
 Ideal for stairs and protecting against heavy furniture indentation  
 Suitable for high traffic areas

**SYSTEM TEN**

TASYSTEM10 **tredaire**

THICKNESS	DENSITY	ROLL WEIGHT	ROLL AREA	HEAT INSULATION	SOUND REDUCTION
9.2 mm	435 kg/m <sup>3</sup>	43.80 kg	10.96 m <sup>2</sup>	1.55 Tog	31 dB



HEAVY CONTRACT USE

Comfort	5 ★★★★★★
Durability	6 ★★★★★★
Warmth	4 ★★★★★
Impact Sound	4 ★★★★★
Airborne Sound	6 ★★★★★★
Underfloor Heating	1 ★

Recycled crumb rubber from car tyres  
 Ideal for natural floorcovering such as coir or sisal  
 Suitable for high traffic areas  
 Stretch-fit, single-stick or double-stick  
 (Single-stick for a maximum area of 33m<sup>2</sup>)  
 Polypropylene backing

**TREADMORE**

TATREADMORE **tredaire**

THICKNESS	DENSITY	ROLL WEIGHT	ROLL AREA	HEAT INSULATION	SOUND REDUCTION
7.95 mm	390 kg/m <sup>3</sup>	34.00 kg	10.96 m <sup>2</sup>	1.03 Tog	32 dB

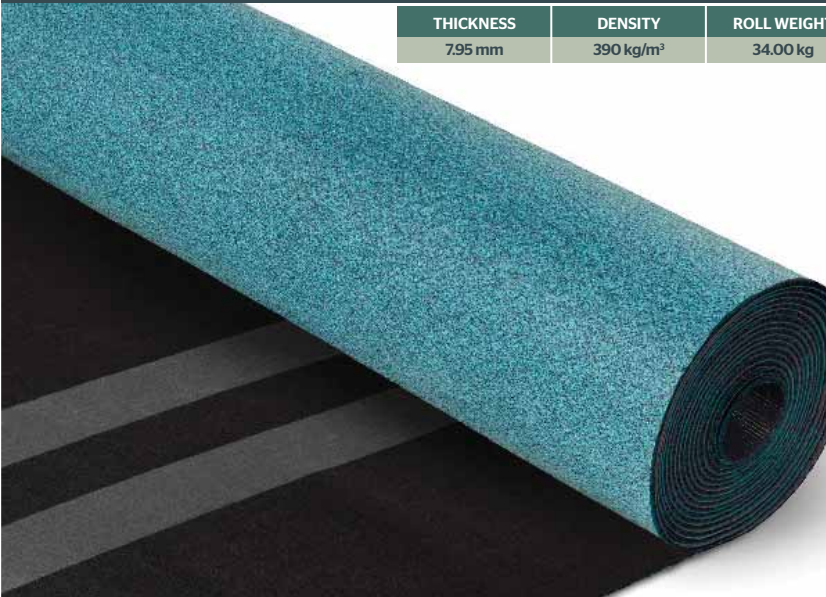

HEAVY CONTRACT USE

Comfort	4 ★★★★★
Durability	6 ★★★★★★
Warmth	3 ★★★
Impact Sound	4 ★★★★★
Airborne Sound	4 ★★★★★
Underfloor Heating	5 ★★★★★

Carpet protection from heavy wear  
 Recycled crumb rubber from car tyres  
 Ideal for stairs and protecting against heavy furniture indentation  
 Suitable for high traffic areas

SERENITY ADVANCE

TASERENITYADVANCE



GENERAL DOMESTIC USE

THICKNESS	DENSITY	ROLL WEIGHT
11.00 mm	218 kg/m <sup>3</sup>	24.00 kg
ROLL AREA	HEAT INSULATION	SOUND REDUCTION
10.00m <sup>2</sup>	2.82 Tog	34 dB

Triple layer residential carpet underlay. Made from a 100% recycled wool fibres waste combined with carpet waste and post - consumer vehicle tyre waste.



Comfort	6 ★★★★★★
Durability	5 ★★★★★★
Warmth	4 ★★★★★
Impact Sound	4 ★★★★★
Airborne Sound	4 ★★★★★
Underfloor Heating	1 ★

KENSINGTON DELUXE®

tredaire

TAKENDEL



HEAVY CONTRACT USE

Kensington Deluxe®

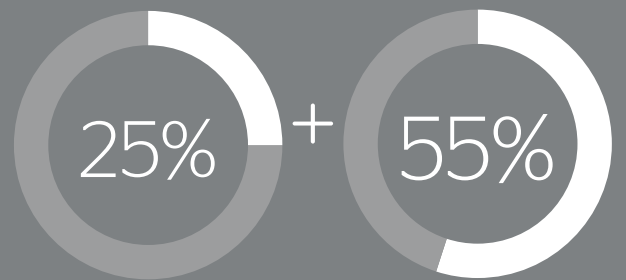

Recycled Plastic    Recycled Car Tyres

This recycled crumb/felt combination creates an underlay with superior wear and comfort properties.

The rubber base is made from recycled car tyres and natural rubber latex. The 'felt' base is made from the polymer PES, containing recycled pre-consumer plastic.

The perfect choice for Wilton and Axminster style carpets. The felt backing means that carpets with stitched joins bed into the top felt layer and prevent wear along the join.

The rubber from one car tyre is recycled for every square metre of Kensington Deluxe.

THICKNESS	DENSITY	ROLL WEIGHT
11.00 mm	227 kg/m <sup>3</sup>	27.40 kg
ROLL AREA	HEAT INSULATION	SOUND REDUCTION
10.96 m <sup>2</sup>	1.70 Tog	30 dB



2306128 Centexbel

Comfort	6 ★★★★★★
Durability	5 ★★★★★★
Warmth	4 ★★★★★
Impact Sound	4 ★★★★★
Airborne Sound	4 ★★★★★
Underfloor Heating	1 ★





- Fast carpet underlay system for almost every carpet
- Prolongs the life of your carpet
- Easily removable without damaging the base floor

**Egalsoft® is a unique anti-slip underlay that provides a durable and easy installation. The carpet underlay is an impregnated nonwoven with an anti-slip equipment.**

- Provides luxury and comfort and extends the service life of the carpet
- Removable system - the perfect solution when nails or glue may not be used
- Good noise reduction (27 dB) and heat-insulating
- Easy to cut, and fast and simple to install
- Also available in fire-retardant quality; Euroclass Bfl-S1
- Suitable for residential, industrial and commercial applications

Since 1993, more than 20 million square metres of Egalsoft® carpet underlay has been installed.

Thanks to the anti-slip properties of Egalsoft® it not only saves on adhesive, but it is quicker and easier to install. Removal is also simple as the carpet and the Egalsoft® are easily removed together.



NAME	Egalsoft 6,5 mm
PRODUCT CODE	TA68240
FLOOR TYPE	Carpet
TYPE BASE FLOOR	Floating screed
THICKNESS	6,5 mm
DIMENSION	22 m x 1,37 m (30,14 m <sup>2</sup> )
WEIGHT PER M <sup>2</sup>	850 gr/ m <sup>2</sup>
DENSITY	131 kg/m <sup>3</sup>
SOUND REDUCING	27 dB Δlw
FIRE RETARDANT	Efl
THERMAL RESISTANCE	2,2 togs - 0,22 m <sup>2</sup> K/W
DOMESTIC	Yes
PROJECT BASE	Yes
MATERIAL	
TOP LAYER	PP spunbond
MIDDLE LAYER	Impregnated non woven
BOTTOM LAYER	Anti-slip equipment



Fast and easy to install over existing floors including tiles or parquet with easy release when access is required

## Sonixx<sup>®</sup> Core Range

Sonixx<sup>®</sup> specialist acoustic underlays significantly reduce sound transmission and have the durability and resilience to remain in situ for decades.

### Resilient 250 (2.5mm)

Soft Floor Covering / Acoustic Underlay  
Impact Sound Reduction: 19 dB ( $\Delta L_w$ ) / IIC 51 /  $\Delta$ IIC 23

Resilient 250 is a versatile, high performing acoustic resilient layer that has been designed to significantly reduce impact sound. The underlay is quick and easy to work with and can be used with a wide range of floor coverings, providing long-lasting acoustic performance and exceptional cushioning support.

TARS250



### Soundsure 400 (4mm)

High Performance Acoustic Underlay  
Impact Sound Reduction: 24 dB ( $\Delta L_w$ ) / IIC 57 /  $\Delta$ IIC 27

Soundsure 400 is an acoustic resilient layer that has been designed predominantly for laminates, wood flooring and carpet tiles, delivering superior impact sound performance.

TASS400A

### Soundsure 560 (5.6mm)

Underscreed Resilient Layer / Acoustic Underlay  
Impact Sound Reduction: 27 dB ( $\Delta L_w$ ) / IIC 56 /  $\Delta$ IIC 28

Soundsure 560 is an acoustic resilient layer that has been designed to isolate floor screeds from the main structure of the building, delivering superior impact and airborne sound performance.

TASS560



### Multi-Fit (1.5mm)

Acoustic Underlay for LVT and Ceramic Tiles  
Impact Sound Reduction: 14 dB ( $\Delta L_w$ ) / IIC 44 /  $\Delta$ IIC 15

LVT Multi-Fit Underlay can be fitted, loose lay, single stick or double stick depending upon your installation requirements. It provides an excellent subfloor, masking minor surface imperfections, and helping prevent the over straining of joints.

TALVTMULTIFIT



Sonixx® acoustic solutions are excellent for use in:

- Private Homes
- Hospitality
- Retail
- Healthcare
- Multi-Family Housing
- Apartments and hotels
- Commercial Developments
- Care Homes
- Schools and Education Projects



**Our Guarantee**  
Backed by a  
10 year guarantee.

Acoustic Performance*	Multi-Fit			Resilient 250			Soundsure 400			Soundsure 560		
	ΔLw	IIC	ΔIIC	ΔLw	IIC	ΔIIC	ΔLw	IIC	ΔIIC	ΔLw	IIC	ΔIIC
No Floor Covering	14	44	15	19	51	23	24	57	27	27	56	28
Luxury Vinyl Tiles (2.5mm)	-	-	-	20	54	24	-	-	-	-	-	-
Luxury Vinyl Tiles (4.5mm)	17	51	21	20	54	24	-	-	-	-	-	-
Luxury Vinyl Tiles (5mm)	21	55	25	21	55	25	-	-	-	-	-	-
Sheet Vinyl (2mm)	-	-	-	18	51	22	-	-	-	-	-	-
Linoleum (2.5mm)	-	-	-	18	52	22	-	-	-	-	-	-
Laminate (8mm)	-	-	-	18	52	22	19	52	23	19	53	23
Laminate (10mm)	17	-	-	-	-	-	-	-	-	-	-	-
Engineered Wood (14mm)	17	-	-	17	51	21	19	53	23	18	52	22
Carpet Tile (Bitumen Backed)	-	-	-	30	64	30	38	68	36	41	69	39
Ceramic Tile (9mm)	-	-	-	17	50	21	-	-	-	-	-	-
Ceramic Tiles (10mm)	16	-	-	-	-	-	-	-	-	-	-	-
Concrete (48mm)	-	-	-	-	-	-	26	60	29	27	60	29
Sand / Cement Screed (75mm)	-	-	-	-	-	-	-	-	-	24	56	26

\* Tested on a 140mm / 5½" thick concrete slab with no ceiling below

Acoustic Performance†	Multi-Fit			Resilient 250			Soundsure 400			Soundsure 560		
	HIIC	IIC	STC	HIIC	IIC	STC	HIIC	IIC	STC	HIIC	IIC	STC
Luxury Vinyl Tiles (4.77mm)	91	72	64	91	73	65	-	-	-	-	-	-
Luxury Vinyl Tiles (5mm)	-	-	-	92	72	64	-	-	-	-	-	-
Engineered Wood (¾")	-	-	-	-	-	-	79	67	60	-	-	-

† Tested with a floor-ceiling assembly - 152mm / 6" thick concrete slab.

Acoustic Performance‡	Multi-Fit			Resilient 250			Soundsure 400			Soundsure 560		
	IIC	ΔIIC	STC	IIC	ΔIIC	STC	IIC	ΔIIC	STC	IIC	ΔIIC	STC
Luxury Vinyl Tiles (5mm)	57	23	54	59	24	54	-	-	-	-	-	-

‡ Tested on a 203mm / 8" thick concrete slab with no ceiling below.

Applications	Multi-Fit	Resilient 250	Soundsure 400	Soundsure 560
Luxury Vinyl & SPC Tiles / Planks (Dryback) ≥ 2.5mm	✓	✓	✗	✗
Luxury Vinyl & SPC Tiles / Planks (Click Joint) ≥ 3.0mm	✓	✓	✗	✗
Woven Vinyl Tiles / Planks (Dryback) ≥ 2.5mm	✓	✓	✗	✗
Loose Lay Vinyl & SPC Tiles / Planks ≥ 3.0mm	✓	✓	✗	✗
Sheet Vinyl (2mm)	✓	✓	✗	✗
Linoleum (2.5mm)	✓	✓	✗	✗
Laminate (Click Joint)	✓	✓	✓ preferred	✓
Engineered Wood (Click Joint / Tongue & Groove)	✓	✓	✓ preferred	✓
Solid Wood (Tongue & Groove)	✗	✓	✗	✗
Bamboo (Tongue & Groove)	✗	✓	✓ preferred	✓
Parquet Flooring (No Joint System)	✗	✓	✓ preferred	✓
Carpet Tiles	✗	✓	✓ preferred	✓
Broadloom Carpet	✗	✓	✗	✗
Natural Floor Coverings	✗	✓	✗	✗
Ceramic / Porcelain / Natural Stone Tiles**	✓	✓	✗	✗
Underscreed Resilient Layer	✗	✗	✓	✓
IMO Certified	✓	✗	✗	✗

\*\* An approved pre-mixed flexible grout must be used for all installations.



## Specialist Acoustic Solutions



### Our Guarantee

Backed by a 60 year guarantee.



# Rubber Crumb Cradles

For Raised Acoustic, Sports Flooring and Decking Applications

Rubber Crumb Cradles are **adaptive, eco-friendly and used extensively in new build, refurbishment and conversion projects.** This versatile system provides quick and precise on-site levelling to achieve a wide range of finished floor heights.

## Advantages of Rubber Crumb Cradles

- 1. Quick, simple and cost effective to install.**  
Cradles are loosely positioned on the subfloor with no fixing required.
- 2. Exceeds the performance standards required in the UK Building Regulations** for airborne and impact sound insulation.
- 3. System can be levelled to an SR1 classification**
- 4. Compliant with EN 14904** – providing combined-elastic and area-elastic floors.
- 5. Complies with Robust Details FFT2**
- 6. Dry and lightweight solution** – eliminates wet trades, helping to streamline programming and on-site processes, as well as reducing structural loadings.
- 8. Increased heights can be achieved** with the use of base packers.
- 9. Accommodates underfloor heating systems,** services and insulation by creating a void.
- 10. Allows access** to hatches and fittings for permanent sports equipment.
- 11. A wide range of floor coverings can be installed** above the system.
- 12. System is maintenance free.**

## The Cradle and Batten System

Designed either as a raised floor, which can house underfloor heating and other services, or as a high performance acoustic and sports floor. The cradles facilitate rapid and easy levelling of uneven subfloors on-site with the use of cradle packers and base packers.

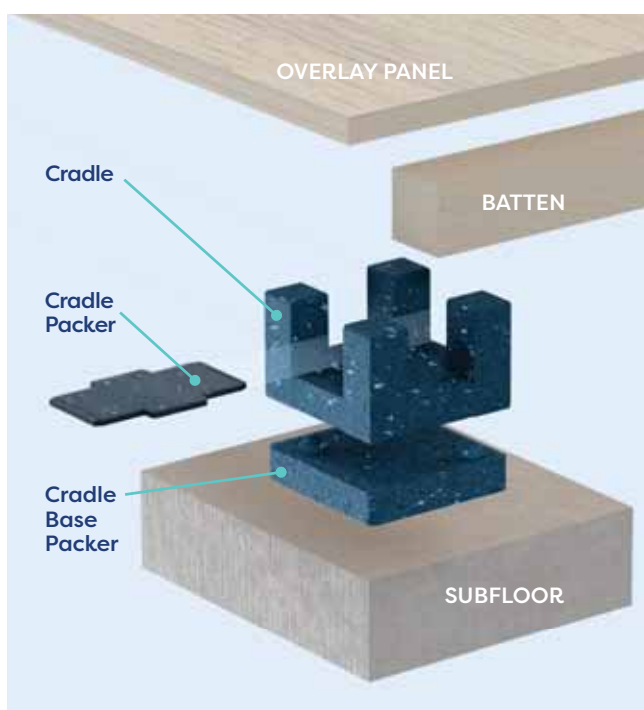

## Rubber Crumb Cradle Applications

Rubber Crumb Cradles can be used across a multitude of projects, such as:

- New build, refurbishment & conversion projects
- Concrete subfloors
- Timber subfloors
- Commercial installations
- Schools
- Sports floors
- Dance floors
- Gyms & free weight areas
- Underfloor heating
- Outside decking
- Access for services

### Sonixx accessory codes

AC2510 RUBBER CRUMB CRADLE 25x10\*150  
AC2520 RUBBER CRUMB CRADLE 25x20\*120  
AC4020 RUBBER CRUMB CRADLE 40x20\*90

BP10 BASE PACKERS 10mm\*162  
BP30 BASE PACKERS 30mm\*54

CP2 CRADLE PACKERS 2mm\*300  
CP3 CRADLE PACKERS 3mm\*200  
CP5 CRADLE PACKERS 5mm\*100





# FR AND IMO UNDERLAYS

## Creating safer public spaces

Public-facing interiors demand an underlay that offers exceptional performance and safety. Our flame retardant range combines resilience and comfort while also providing specifiers with trusted products known for their reliability. Reflecting the strictest flammability safety standards, Interfloor flame retardant underlays have been used extensively in hotels and cruise liners across the globe.

## Take comfort in safety

An IMO rated underlay guarantees that the product has been tested and certified in accordance with International Maritime Organization guidelines. These underlays are designed to be as lightweight as possible to minimise fuel costs and pass the IMO's surface flammability, smoke and toxicity requirements.

**DURAFIT 500** TADURAFIT500 **Duralay**

THICKNESS	DENSITY	ROLL WEIGHT	ROLL AREA	HEAT INSULATION	SOUND REDUCTION
5.25 mm	400 kg/m <sup>3</sup>	31.60 kg	15.07 m <sup>2</sup>	0.83 Tog	26 dB



Contract quality carpet underlay  
 Flame retardant carpet underlay  
 Suitable for underfloor heating  
 Recycled crumb rubber from car tyres  
 Perfect for high traffic areas & border-work  
 Double-stick & stretch-fit  
 Polypropylene backing

**HEAVY CONTRACT USE**

**Flame Retardant\***

Comfort	3 ★★ ★
Durability	6 ★★ ★★ ★★
Warmth	2 ★★
Impact Sound	4 ★★ ★★
Airborne Sound	3 ★★ ★
Underfloor Heating	5 ★★ ★★ ★

**DURAFIT 650** TADURAFIT650 **Duralay**

THICKNESS	DENSITY	ROLL WEIGHT	ROLL AREA	HEAT INSULATION	SOUND REDUCTION
6.50 mm	415 kg/m <sup>3</sup>	40.08 kg	15.07 m <sup>2</sup>	1.10 Tog	28 dB



Contract quality carpet underlay  
 Flame retardant carpet underlay  
 Recycled crumb rubber from car tyres  
 Perfect for high traffic areas & border-work  
 Double-stick & stretch-fit  
 Polypropylene backing

**HEAVY CONTRACT USE**

**Flame Retardant\***

Comfort	4 ★★ ★★
Durability	6 ★★ ★★ ★★
Warmth	3 ★★ ★
Impact Sound	4 ★★ ★★
Airborne Sound	4 ★★ ★★
Underfloor Heating	5 ★★ ★★ ★

**FR6** TAFR6 **tredaire**

THICKNESS	DENSITY	ROLL WEIGHT	ROLL AREA	HEAT INSULATION	SOUND REDUCTION
6.00 mm	200 kg/m <sup>3</sup>	18.8 kg	15.07 m <sup>2</sup>	1.68 Tog	35 dB



Premium high density plus  
 Flame retardant carpet underlay  
 PU foam carpet underlay  
 Double-stick and stretch-fit  
 100% recycled foam

**Flame Retardant**

Comfort	4 ★★ ★★
Durability	5 ★★ ★★ ★
Warmth	4 ★★ ★★
Impact Sound	4 ★★ ★★
Airborne Sound	2 ★★
Underfloor Heating	1 ★
Flame Retardancy	5 ★★ ★★ ★

**FR7** TAFR7 **tredaire**

THICKNESS	DENSITY	ROLL WEIGHT	ROLL AREA	HEAT INSULATION	SOUND REDUCTION
7.00 mm	145 kg/m <sup>3</sup>	15.3 kg	15.07 m <sup>2</sup>	1.99 Tog	34 dB



Premium high density  
 Flame retardant carpet underlay  
 PU foam carpet underlay  
 Double-stick and stretch-fit  
 100% recycled foam

**Flame Retardant**

Comfort	4 ★★ ★★
Durability	5 ★★ ★★ ★
Warmth	4 ★★ ★★
Impact Sound	4 ★★ ★★
Airborne Sound	2 ★★
Underfloor Heating	1 ★
Flame Retardancy	5 ★★ ★★ ★

**TECHNICS 5** TATECH5 **Duralay**

THICKNESS	DENSITY	ROLL WEIGHT	ROLL AREA	HEAT INSULATION	SOUND REDUCTION
5.00 mm	542 kg/m <sup>3</sup>	40.90 kg	15.07 m <sup>2</sup>	0.56 Tog	28 dB



High-traffic flame retardant carpet underlay  
 Flame retardant carpet underlay  
 Sponge rubber  
 Perfect for high traffic areas & border-work  
 Suitable for underfloor heating  
 Double-stick & stretch fit

**Flame Retardant\***

Comfort	3 ★★ ★
Durability	5 ★★ ★★ ★
Warmth	2 ★★
Impact Sound	4 ★★ ★★
Airborne Sound	4 ★★ ★★
Underfloor Heating	6 ★★ ★★ ★★
Flame Retardancy	6 ★★ ★★ ★★

\*Must be fitted as a double-stick installation to achieve flame retardancy. Note: All FR Products achieve a minimum of Cf-s1 when tested to EN13 501



THICKNESS	DENSITY	ROLL WEIGHT	ROLL AREA	HEAT INSULATION	SOUND REDUCTION
6.00 mm	525 kg/m <sup>3</sup>	47.5 kg	15.07 m <sup>2</sup>	0.66 Tog	34dB

Comfort	4 ★★★★★
Durability	5 ★★★★★
Warmth	2 ★★
Impact Sound	4 ★★★★★
Airborne Sound	4 ★★★★★
Underfloor Heating	6 ★★★★★★
Flame Retardancy	6 ★★★★★★

**Flame Retardant\***

High-traffic flame retardant carpet underlay  
 Sponge rubber  
 Perfect for high traffic areas & border-work  
 Suitable for underfloor heating  
 Double-stick & stretch fit



**FLAMECHECK 4** TAFLAMECHECK4 **tredaire**

THICKNESS	DENSITY	ROLL WEIGHT	ROLL AREA	HEAT INSULATION	SOUND REDUCTION
4.00 mm	145 kg/m <sup>3</sup>	9.3 kg	15.07 m <sup>2</sup>	1.02 Tog	26 dB



Ultra high density  
Flame retardant carpet underlay  
Polyethylene/flame retardant non-woven scrim  
Suitable for heavy contract use  
Double-stick and stretch-fit  
100% recycled foam

IMO & Flame Retardant

Comfort	3 ★★★★★
Durability	5 ★★★★★
Warmth	3 ★★★★★
Impact Sound	4 ★★★★★
Airborne Sound	2 ★★★★★
Underfloor Heating	1 ★★★★★
Flame Retardancy	6 ★★★★★

**FLAMECHECK 6** TAFLAMECHECK6 **tredaire**

THICKNESS	DENSITY	ROLL WEIGHT	ROLL AREA	HEAT INSULATION	SOUND REDUCTION
6.00 mm	145 kg/m <sup>3</sup>	14.0 kg	15.07 m <sup>2</sup>	1.58 Tog	30 dB



Ultra high density  
Flame retardant carpet underlay  
Polyethylene/flame retardant non-woven scrim  
Suitable for heavy contract use  
Double-stick and stretch-fit  
100% recycled foam

IMO & Flame Retardant

Comfort	4 ★★★★★
Durability	5 ★★★★★
Warmth	4 ★★★★★
Impact Sound	4 ★★★★★
Airborne Sound	2 ★★★★★
Underfloor Heating	1 ★★★★★
Flame Retardancy	6 ★★★★★

**FLAMECHECK 8** TAFLAMECHECK8 **tredaire**

THICKNESS	DENSITY	ROLL WEIGHT	ROLL AREA	HEAT INSULATION	SOUND REDUCTION
8.00 mm	145 kg/m <sup>3</sup>	18.3 kg	15.07 m <sup>2</sup>	1.99 Tog	34 dB



Ultra-high density underlay  
Flame retardant carpet underlay  
Polyethylene/Flame retardant 85gsm crepe paper  
Double-stick and stretch-fit  
100% recycled foam

HEAVY CONTRACT USE

IMO & Flame Retardant

Comfort	5 ★★★★★
Durability	5 ★★★★★
Warmth	4 ★★★★★
Impact Sound	4 ★★★★★
Airborne Sound	2 ★★★★★
Underfloor Heating	1 ★★★★★
Flame Retardancy	6 ★★★★★

**LVT MULTI-FIT** TALVTMULTIFIT **Duralay**

THICKNESS	DENSITY	ROLL WEIGHT	ROLL AREA	HEAT INSULATION	SOUND REDUCTION
1.5 mm	1667 kg/m <sup>3</sup>	25.00 kg	10.00 m <sup>2</sup>	0.12 Tog	14 dB



IMO rated flame retardant underlay for LVT & SPC  
Sponge rubber luxury vinyl tile underlay  
Suitable for underfloor heating  
Helps prevent the overstraining of joints

IMO & Flame Retardant\*

Impact Sound	6 ★★★★★
Airborne Sound	4 ★★★★★
Underfloor Heating	6 ★★★★★
Flame Retardancy	6 ★★★★★

\*Must be fitted as a double-stick installation to achieve flame retardancy.  
Note: All FR Products achieve a minimum of Cfl-s1 when tested to EN13 501

## Technical Specification

Complete technical specification for our underlays can be found at:

[interfloor.com/technical-specification](http://interfloor.com/technical-specification)

...or simply scan the QR code with your phone.

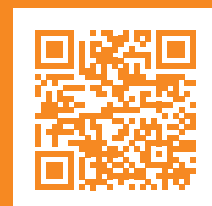

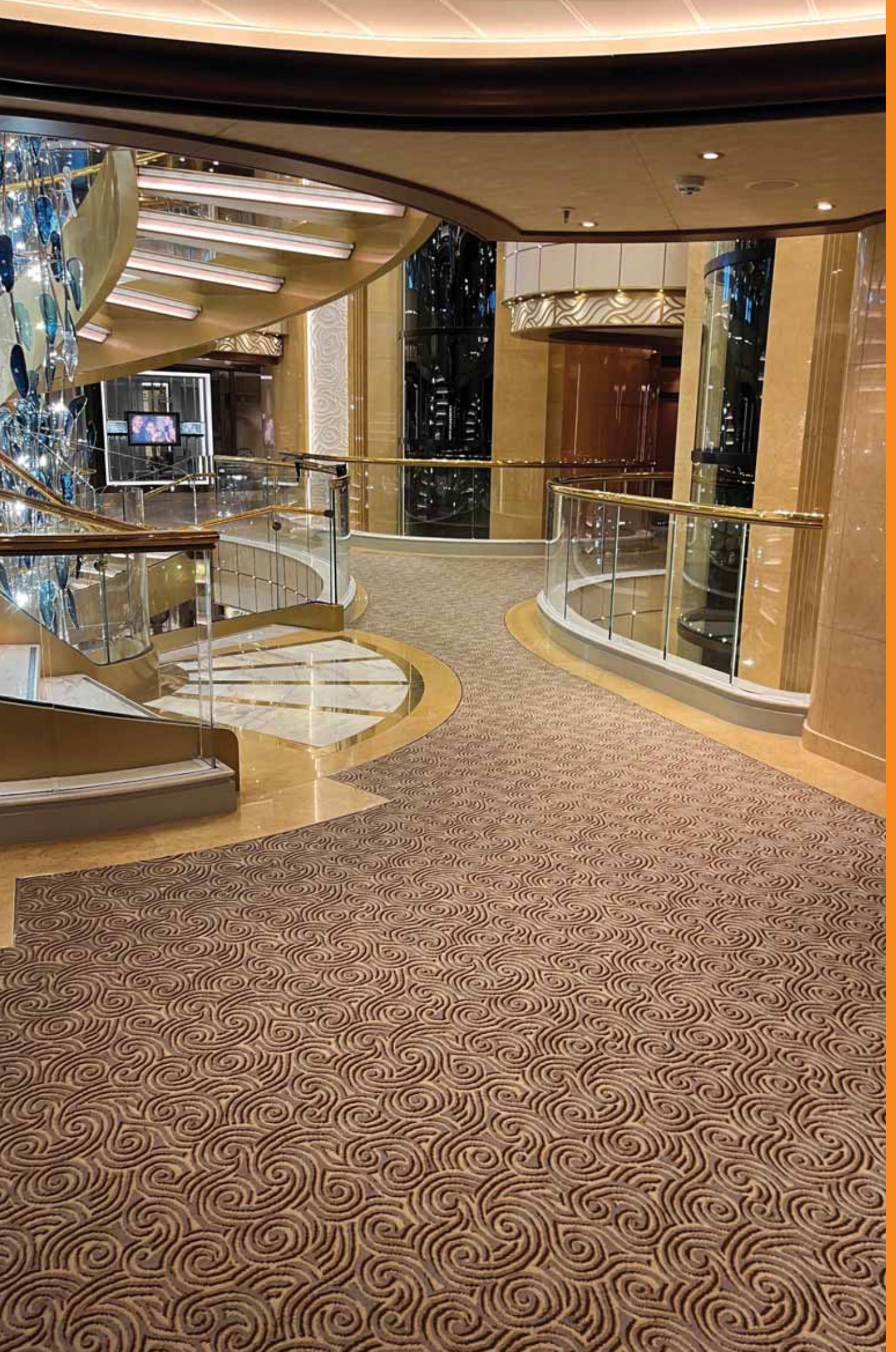

# HARD FLOORING UNDERLAYS

## LVT & SPC Underlay

The beauty of click-fit LVT & SPC flooring is in its quick installation and our compatible underlays are no different. Designed to significantly reduce sub-floor preparation times, our underlays create a level surface for dry-back and click-fit LVT & SPC flooring.

## Wood & Laminate Underlay

Echoes and amplified footfall are common issues for wood and laminate surfaces. Interfloor's specialised underlay range is able to reduce in-room noise by up to 30% whilst reducing movement and wear on the boards.



# Duralay

## Luxury vinyl tile underlays

- Significantly reduce sub-floor preparation times
- Simple, quick and easy to install
- Increased underfoot comfort
- Improved noise reduction



UNDERFLOOR HEATING TYPE	SUITABILITY
Embedded water pipes in floor / floor screed	✓
Amorphous ribbon heating mats on top of structural floor	✓
Electric cable buried in screed or within suspended timber floor	Check with manufacturer of heating system
Electric heating mats on top of structural floor	✗

### LVT MULTI-FIT



THICKNESS	DENSITY	ROLL WEIGHT	ROLL AREA	HEAT INSULATION	SOUND REDUCTION
1.50 mm	1667 kg/m <sup>3</sup>	25.00 kg	10.00 m <sup>2</sup>	0.12 Tog	14 dB

IMO rated flame retardant underlay for LVT & SPC, see page 48  
For all types of LVT flooring  
Reduces in-room noise  
Smooths floor unevenness





TALVTMULTIFIT **Duralay**

	Impact Sound	Airborne Sound	Underfloor Heating
	6 ★★★★★★	4 ★★★★★	6 ★★★★★★

Note: All FR Products achieve a minimum of Cfl-s1 when tested to EN13501

### LVT LOW-GRAB



THICKNESS	DENSITY	ROLL WEIGHT	ROLL AREA	HEAT INSULATION	SOUND REDUCTION
1.50 mm	1000 kg/m <sup>3</sup>	15.00 kg	10.00 m <sup>2</sup>	0.10 Tog	17 dB

For all click-system LVT & SPC  
Reduces in-room noise  
Smooths floor unevenness  
Non-slip surface to prevent movement

TALVTLOWGRAB **Duralay**

	Impact Sound	Airborne Sound	Underfloor Heating
	6 ★★★★★★	2 ★★	6 ★★★★★★

### LVT DRY-BACK



THICKNESS	DENSITY	ROLL WEIGHT	ROLL AREA	HEAT INSULATION	SOUND REDUCTION
1.80 mm	1444 kg/m <sup>3</sup>	16.25 kg	6.50 m <sup>2</sup>	0.10 Tog	15 dB

For dry-back LVT & SPC  
Reduces in-room noise  
Smooths floor unevenness  
Self-adhesive layer with peel-back film

TALVTDYRBACK **Duralay**

	Impact Sound	Airborne Sound	Underfloor Heating
	6 ★★★★★★	4 ★★★★★	6 ★★★★★★

## Technical Specification

Complete technical specification for our underlays can be found at: [interfloor.com/technical-specification](http://interfloor.com/technical-specification) ...or simply scan the QR code with your phone.



# Wood and laminate underlays

- Protects against wear and tear
- Prevents loose boards moving
- Smooths out subfloor imperfections
- Supports board joints
- Reduces in-room noise up to 30%
- Quick & easy to install
- Prevents moisture damage
- Adds extra insulation

**MULTITEX** TADM146068 **Duralay**



THICKNESS	DENSITY	ROLL WEIGHT	ROLL AREA	HEAT INSULATION	SOUND REDUCTION
3.60 mm	706 kg/m <sup>3</sup>	25.40 kg	10.00 m <sup>2</sup>	0.57 Tog	23 dB

Hard flooring underlay  
Reduces in-room noise by up to 30%  
Smooths floor unevenness  
**Suitable for underfloor heating**

Impact Sound	5 ★★★★★★
Airborne Sound	4 ★★★★★
Underfloor Heating	4 ★★★★★

**SERENITY UNDERWOOD** TATXL14668



THICKNESS	DENSITY	ROLL WEIGHT	ROLL AREA	HEAT INSULATION	SOUND REDUCTION
3.50 mm	360 kg/m <sup>3</sup>	12.60 kg	10.00 m <sup>2</sup>	0.80 Tog	23 dB

Hard flooring underlay  
Reduces in-room noise  
Smooths floor unevenness  
Moisture-preventing Vapourstop backing  
Sustainably made with recycled car tyres  
**Low tog rating Suitable for underfloor heating**



Impact Sound	5 ★★★★★★
Airborne Sound	4 ★★★★★
Underfloor Heating	4 ★★★★★
Moisture Resistance	6 ★★★★★★

**TIMBERMATE EXCEL DIY** TATXL14668 **Duralay**



THICKNESS	DENSITY	ROLL WEIGHT	ROLL AREA	HEAT INSULATION	SOUND REDUCTION
3.60 mm	707 kg/m <sup>3</sup>	25.60 kg	10.00 m <sup>2</sup>	0.55 Tog	23 dB

Hard flooring underlay  
Reduces in-room noise by up to 30%  
Smooths floor unevenness  
Moisture-preventing Vapourstop backing  
**Suitable for underfloor heating**

Impact Sound	5 ★★★★★★
Airborne Sound	4 ★★★★★
Underfloor Heating	4 ★★★★★
Moisture Resistance	6 ★★★★★★

**TIMBERMATE EXCEL** TATEX11013 **Duralay**



THICKNESS	DENSITY	ROLL WEIGHT	ROLL AREA	HEAT INSULATION	SOUND REDUCTION
3.60 mm	707 kg/m <sup>3</sup>	38.30 kg	15.07 m <sup>2</sup>	0.55 Tog	23 dB

Hard flooring underlay  
Reduces in-room noise by up to 30%  
Smooths floor unevenness  
Moisture-preventing Vapourstop backing  
**Suitable for underfloor heating**

Impact Sound	5 ★★★★★★
Airborne Sound	4 ★★★★★
Underfloor Heating	4 ★★★★★
Moisture Resistance	6 ★★★★★★

**SILENTFLOOR GOLD** TASILGOLD2 **Duralay**



THICKNESS	DENSITY	ROLL WEIGHT	ROLL AREA	HEAT INSULATION	SOUND REDUCTION
4.20 mm	710 kg/m <sup>3</sup>	29.90 kg	10.00 m <sup>2</sup>	0.33 Tog	24 dB

Hard flooring underlay  
Reduces in-room noise by up to 30%  
Smooths floor unevenness  
Moisture-preventing Vapourstop backing  
**Suitable for underfloor heating**

Impact Sound	6 ★★★★★★
Airborne Sound	4 ★★★★★
Underfloor Heating	6 ★★★★★★
Moisture Resistance	6 ★★★★★★

**HEATFLOW WOOD & LAMINATE**

TAHEATWOOD

**Duralay**



Best in class

THICKNESS	DENSITY	ROLL WEIGHT	ROLL AREA	HEAT INSULATION	SOUND REDUCTION
3.00 mm	802 kg/m <sup>3</sup>	36.20 kg	15.07 m <sup>2</sup>	0.35 Tog	21 dB

Hard flooring underlay  
Reduces in-room noise  
Smooths floor unevenness  
Stitched kraft paper backing  
Suitable for underfloor heating

Impact Sound	5	★★★★★
Airborne Sound	4	★★★★★
Underfloor Heating	6	★★★★★★

**ALL IN ONE**

All In One underlay is composed of a light 3mm polyethylene with an integral damp proof membrane whose thermal and sound insulation qualities are ideal for wood and laminate floors. Atoxic, odourless and chemically inert, All In One does not leave stains and offers an efficient resistance to pressure, repeated shocks and chemicals.

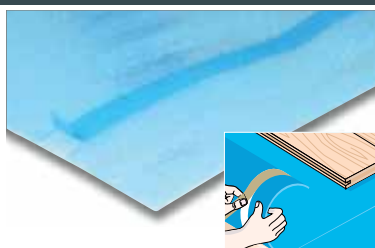

**FEATURES**

- 3mm Polyethylene
- Noise reduction of 20 dB
- Excellent thermal and shock insulator
- Integral damp proof membrane
- Integral self-adhesive fixing tape
- Odourless and non staining

**SPECIFICATION**

SIZE:	<b>1m X 10m</b>
ROLL COVERAGE:	<b>10m<sup>2</sup></b>
THICKNESS:	<b>3mm</b>
PACK OF 8 ROLLS:	<b>EW310</b>

**SILVERLAY**

2mm polyethylene foam underlay with built-in silver foil moisture barrier and self-adhesive overlap. Silverlay wood and laminate underlay is composed of a polyethylene foam, which is laminated with an integral overlapping silver metallised polypropylene film damp proof membrane of 20 micron.

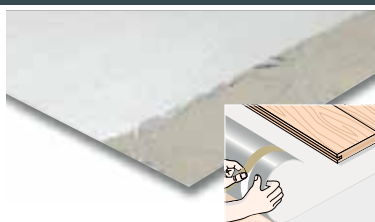

**FEATURES**

- 2mm Polyethylene
- Noise reduction of 18 dB
- Excellent thermal and shock insulator
- 10cm overlapping moisture barrier membrane
- Integral self-adhesive fixing tape
- Odourless and non staining

**SPECIFICATION**

SIZE:	<b>10m X 1m</b>
ROLL COVERAGE:	<b>10m<sup>2</sup></b>
THICKNESS:	<b>2mm</b>
PACK OF 8 ROLLS:	<b>EW410</b>

**PLASTIFOAM WHITE**

A light polyethylene underlay suitable for use under wood or laminate floors.



**FEATURES**

- 1.8mm Polyethylene
- Noise reduction of 18 dB
- Easy to fit

**SPECIFICATION**

SIZE:	<b>10m X 1m</b>
ROLL COVERAGE:	<b>10m<sup>2</sup></b>
THICKNESS:	<b>1.8mm</b>
PACK OF 8 ROLLS:	<b>EW210</b>

\*The nominal roll dimensions and area have been quoted.



**Resilient 250 (2.5mm)**

Soft Floor Covering / Acoustic Underlay  
Impact Sound Reduction: 19 dB (ΔLw) / IIC 51 / ΔIIC 23

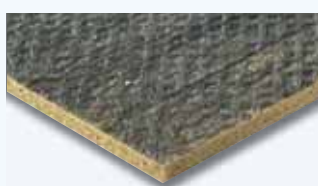

Resilient 250 is a versatile, high performing acoustic resilient layer that has been designed to significantly reduce impact sound. The underlay is quick and easy to work with and can be used with a wide range of floor coverings, providing long-lasting acoustic performance and exceptional cushioning support.

**TARS250**

**Soundsure 400 (4mm)**

High Performance Acoustic Underlay  
Impact Sound Reduction: 24 dB (ΔLw) / IIC 57 / ΔIIC 27

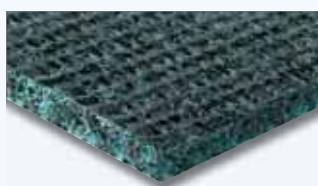

Soundsure 400 is an acoustic resilient layer that has been designed predominantly for laminates, wood flooring and carpet tiles, delivering superior impact sound performance.

**TASS400A**





# UNDERFLOOR HEATING UNDERLAYS

## The underfloor heating essential

In order for underfloor heating systems to run effectively, they always need to be paired with an underlay engineered for the task at hand. Our specialist range ensures that floors still feel wonderfully comfortable underfoot but also allow heat to flow into the room.

## Essential for efficiency

The high insulation level of a standard underlay would stifle any warmth from an underfloor heating system, causing it to run inefficiently and inflate running costs. To maximise the benefits of underfloor heating in any space, we offer professional solutions for both carpet and hard-wood flooring, all with quick and simple installation.

# Low tog wood & laminate underlay for underfloor heating



HEATFLOW WOOD & LAMINATE

**Duralay**

TAHEATWOOD



0.35  
TOG

A specialist low-tog underlay from Duralay for wood and laminate flooring that brings a warm glowing feeling to any floor.

Duralay Heatflow underlays all have lower tog ratings, which allow the warmth generated by underfloor heating to pass quickly into the room. They conduct more heat than other underlays, making them the ideal choice for efficient underfloor heating installations, offering potentially lower heating bills and reduced energy use.

THICKNESS	DENSITY	ROLL WEIGHT
3.00 mm	802 kg/m <sup>3</sup>	36.20 kg
ROLL AREA	HEAT INSULATION	SOUND REDUCTION
15.07 m <sup>2</sup>	0.35 Tog	21 dB

Impact Sound	4 ★★★★★
Airborne Sound	4 ★★★★★
Underfloor Heating	6 ★★★★★★

We do not recommend an underlay is used with an electric mat (or dry) underfloor heating system.

## Technical Specification

Complete technical specification for our underlays can be found at: [interfloor.com/technical-specification](http://interfloor.com/technical-specification) ...or simply scan the QR code with your phone.



# Low tog carpet underlays for underfloor heating

Our very best underlays for underfloor heating systems, giving greater efficiency and the potential to reduce energy bills.



UNDERFLOOR HEATING TYPE	SUITABILITY
Embedded water pipes in floor/floor screed	✓
Amorphous ribbon heating mats on top of structural floor	✓
Electric cable buried in screed or within suspended timber floor	Check with manufacturer of heating system
Electric heating mats on top of structural floor	✗

## HEATFLOW CARPET **Duralay**

TAHEATCARPET2



0.75 TOG

THICKNESS	DENSITY	ROLL WEIGHT
6.10 mm	495 kg/m <sup>3</sup>	30.2 kg
ROLL AREA	HEAT INSULATION	SOUND REDUCTION
10.00 m <sup>2</sup>	0.75 Tog	31 dB

Comfort	4 ★★★★★
Durability	5 ★★★★★
Warmth	2 ★★
Impact Sound	4 ★★★★★
Airborne Sound	4 ★★★★★
Underfloor Heating	6 ★★★★★★

We do not recommend an underlay is used with an electric mat (or dry) underfloor heating system.

## KING **tredaire**

TADK080013



0.80 TOG

THICKNESS	DENSITY	ROLL WEIGHT
8.30 mm	511 kg/m <sup>3</sup>	46.50 kg
ROLL AREA	HEAT INSULATION	SOUND REDUCTION
10.96 m <sup>2</sup>	0.80 Tog	42 dB

Comfort	5 ★★★★★
Durability	6 ★★★★★★
Warmth	2 ★★
Impact Sound	6 ★★★★★★
Airborne Sound	6 ★★★★★★
Underfloor Heating	6 ★★★★★★



## The Cradle and Batten System

Designed either as a raised floor, which can house underfloor heating and other services, or as a high performance acoustic and sports floor. The cradles facilitate rapid and easy levelling of uneven subfloors on-site with the use of cradle packers and base packers.

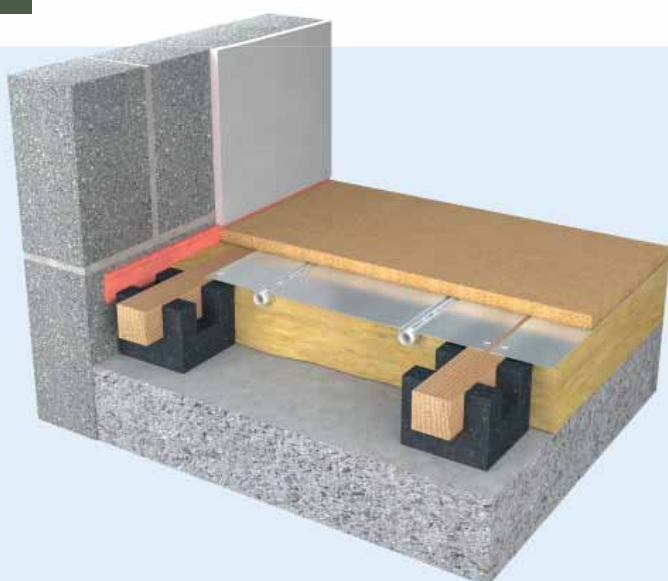



# The Floorfixx dry levelling system



Floorfixx is the underlay range for rigid core, linoleum, cushion vinyl, LVT, LVT click, carpet, carpet tiles and parquet flooring. These underlays allow you to easily create a new, insulating and flat subfloor with a dry installation. Furthermore, these underlays can bear load immediately, there is no need to wait until it is dry. This is a major advantage compared to wet levelling. Time saving, simple and clean. And no long drying or waiting times.

- Fast levelling system
- Immediately ready to finish your floor
- Simple to install as a floating system
- Reduces noise
- You can create a high quality, flat, stable, and permanently dry base floor with underlays
- Meet noise requirements
- Underlays lengthen the lifespan of your floor covering

## Floorfixx regular 9 mm floorfixx regular TX62200



**Description** Floorfixx regular is a system floor that, with the help of the sandwich system and interactive adhesive, quickly and easily creates a new, insulating and even underlay

**Type of floor** Rigid Core, linoleum, cushion vinyl, LVT strips, carpet and carpet tiles

**Material** MDF-XPS 6050 gram/m<sup>2</sup>  
**10 dB label** yes

**installation plan:**  
figure (a)

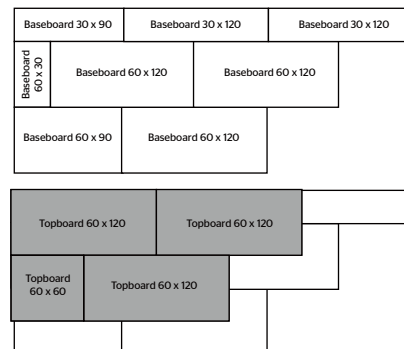

Thickness mm	Length m	Width m	Content m <sup>2</sup>	Fire delay Bfl-S1	Impact sound reduction dB	Levelling capability mm	Pressure resistance kPa/m <sup>2</sup>	Heat resistance m <sup>2</sup> k/W	Density kg/m <sup>3</sup>
9	1,20	0,60	2,88	Bfl-S1	22	2,00	251	0,133	720

## Floorfixx comfort 10 mm floorfixx comfort TX62210



**Description** Floorfixx comfort is a system floor suitable for heavier commercial use and in combination with underfloor heating.

**Type of floor** Linoleum, cushion vinyl, PVC, carpet, carpet tiles and parquet flooring

**Material** MDF-XPS 6900 gram/m<sup>2</sup>  
**Underfloor heating** yes  
**10 dB label** yes

**installation plan:** See figure (a)

Thickness mm	Length m	Width m	Content m <sup>2</sup>	Fire delay Bfl-S1	Impact sound reduction dB	Levelling capability mm	Pressure resistance kPa/m <sup>2</sup>	Heat resistance m <sup>2</sup> k/W	Density kg/m <sup>3</sup>
10	1,20	0,60	2,88	Bfl-S1	20	1,00	168	0,081	720

### Moisture barrier 160 µm TX69780 Roll Size: 100m<sup>2</sup>



The vapour barrier is produced from 100% recycled PE film. Its smooth surface and colour help distinguish the moisture-resistant layer from the original subfloor.

# Gripperrods®



## CARPET GRIPPERS

Gripperrods® is one of the best-known flooring brands in the UK, offering quality, consistency, and reliability.



With a comprehensive product range for fitters and specifiers, they provide solutions for all sub-floor types and flooring styles, with precision pre-nailed grippers that make installation effortless.

Gripperrods® products are designed to deliver a high quality carpet fitting and provide the extra finishing touches to ensure every installation looks its best. Synonymous with professional results, Gripperrods® products are manufactured in the UK to impeccable standards. A brand trusted by consumers and the flooring trade throughout the world.



# A BRIEF GUIDE TO THE GRIPPERRODS® RANGE

## GRIPPERRODS® PROFESSIONAL GRIPPER

Manufactured in the UK from 6mm 5ply plywood, a hardwood plywood of consistent density. 27.1mm wide strip with 79 pins and 13 floor nails gives exceptional holding power and stability on all sub-floors coupled with higher strength in heavy stretch installations.

## GRIPPERRODS® TACKFAST® GRIPPER

Manufactured in the UK, a 6mm 5ply plywood which has a 24.3mm wide strip with 72 pins and 11 floor nails. Designed with a pronounced bevel edge for an easy and consistent roll edge finish. The nails are made to exacting hardness standards to penetrate and hold in any sub-floor and the precision pins are designed for the carpet holding strength required. It is available in all three pin heights and floor nail specifications.

## GRIPPERRODS® STANDARD GRIPPER

Manufactured in the UK from 5.5mm plywood and has a 20mm wide strip with 69 pins, 10 floor nails and has a pronounced bevel edge. Available in medium pin only with wood, concrete or dual-purpose floor nails.

## GRIPPERRODS® REGULAR PLUS GRIPPER

9mm 7ply plywood which has a 22mm wide strip with 72 pins, 11 floor nails and has a pronounced bevel edge. Available in medium pin only with wood or dual-purpose floor nails.

## GRIPPERRODS® FLOORWORKS FELT BACK CARPET GRIPPER

Manufactured in the UK, a 6mm 5ply plywood. 22mm wide strip with a Microplast tape top surface allowing excellent holding power on felt back carpet installations. Available in two variants, Floorworks gripper gives the best finished appearance and wear characteristics for these carpet types. The recommended installation method for fitting underlay with felt backed carpets.

## GRIPPERRODS® WOOD NEAT EDGE (BLIND GRIPPER)

This gripper enables the installer to create the perfect finished appearance around the wall for single and double-stick installations. Manufactured in the UK from 6mm 5ply plywood, 22mm wide strip with dual purpose pre-nails but no pins.

## GRIPPERRODS® CONTRACT GRIPPER

Manufactured in the UK, a 6mm 5ply plywood specialist product for particularly heavy stretch installations. It is 42mm wide and has 126 carpet holding pins in 3 rows compared to the 2 rows in other gripper specifications.



For heavy reinforced backed carpets used in commercial situations.

100 x 1.52m (5') Lengths  
152m (500') Per Carton

The most popular pin length, suitable for most types of carpets.

100 x 1.52m (5') Lengths  
152m (500') Per Carton

For cord carpeting and some low tuft carpets.

100 x 1.52m (5') Lengths  
152m (500') Per Carton

**PROFESSIONAL GRIPPER®**



**Stick Down**

Our top quality stick down professional gripper is ideal for use on modern wooden staircases where fixing by nails is unsuitable. It is ideal for applications where special fixing methods are required. 27.1mm wide strip with 79 pins.

**Pre-nailed for wood floors**

Pre-nailed for ease and speed of installation when fitted to boarded or suspended timber floors, with specially tempered nails (threaded for holding power), pre-driven into the gripper. 27.1mm wide strip with 79 pins and 13 floor nails giving exceptional holding power.

**Pre-nailed for concrete floors**

Designed for ease of installation on concrete floors. Pre-nailed with high quality masonry nails for a firm fixing. 27.1mm wide strip with 79 pins and 13 floor nails giving exceptional holding power.

**Long Pin 6.4mm (1/4")**

**P210** Long Pin and No Nail

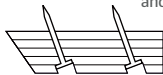

**P220** Long Pin and Wood Nail

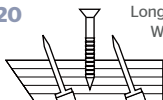

**P240** Long Pin and Masonry Nail



**Medium Pin 4.8mm (3/16")**

**P110** Medium Pin and No Nail



**P120** Medium Pin and Wood Nail

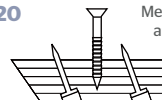

**P140** Medium Pin and Masonry Nail

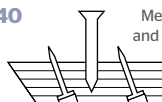

**Short Pin 3.2mm (1/8")**

**P020** Short Pin and Wood Nail



**TACKFAST GRIPPER™**



**Stick Down**

Stick down Tackfast is ideal for use on modern wooden staircases where fixing by nails is unsuitable. It is ideal for applications where special fixing methods are required. 24.3mm wide strip with 72 pins.

**Pre-nailed for wood floors**

Pre-nailed for ease and speed of installation when fitted to boarded or suspended timber floors, with specially tempered nails (threaded for holding power), pre-driven into the gripper. 24.3mm wide strip with 72 pins and 11 floor nails.

**Pre-nailed for concrete floors**

Designed for ease of installation on concrete floors. Pre-nailed with high quality masonry nails for a firm fixing. 24.3mm wide strip with 72 pins and 11 floor nails.

**Dual Purpose**

Pre-nailed with dual purpose nails. Suitable for most wood and concrete based floors. 24.3mm wide strip with 72 pins and 11 floor nails.

**Long Pin 6.4mm (1/4")**

**T210** Long Pin and No Nail



**T220** Long Pin & Wood Nail



**T240** Long Pin & Masonry Nail



**T270** Long Pin & Dual Purpose Nail



**Medium Pin 4.8mm (3/16")**

**T110** Medium Pin and No Nail



**T120** Medium Pin and Wood Nail



**T140** Medium Pin and Masonry Nail



**T170** Medium Pin and Dual Purpose Nail



**Short Pin 3.2mm (1/8")**

**T020** Short Pin & Wood Nail



**T040** Short Pin & Masonry Nail



## STANDARD GRIPPER

### Pre-nailed for wood floors

Pre-nailed for ease and speed of installation when fitted to boarded or suspended timber floors, with specially tempered nails (threaded for holding power), pre-driven into the gripper. 20mm wide strip with 69 pins and 10 floor nails.

### Pre-nailed for concrete floors

Designed for ease of installation on concrete floors. Pre-nailed with high quality masonry nails for a firm fixing. 20mm wide strip with 69 pins and 10 floor nails.

### Dual Purpose

Pre-nailed with dual purpose nails. Suitable for most wood and concrete based floors. 20mm wide strip with 69 pins and 10 floor nails.

100 x 1.52m (5') Lengths  
152m (500') Per Carton



Medium Pin 4.8mm (3/16")

S120

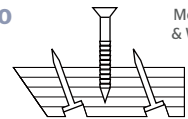

Medium Pin & Wood Nail

S140

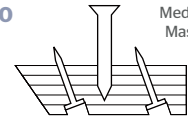

Medium Pin & Masonry Nail

S170

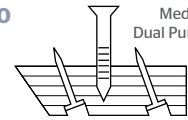

Medium Pin & Dual Purpose Nail

## REGULAR PLUS GRIPPER (9MM)

### Pre-nailed for wood floors

Pre-nailed for ease and speed of installation when fitted to boarded or suspended timber floors, with specially tempered nails (threaded for holding power), pre-driven into the gripper. 22mm wide strip with 72 pins and 11 floor nails.

### Dual Purpose

Pre-nailed with dual purpose nails. Suitable for most wood and concrete based floors. 22mm wide strip with 72 pins and 11 floor nails.

80 x 1.52m (5') Lengths  
122m (400') Per Carton

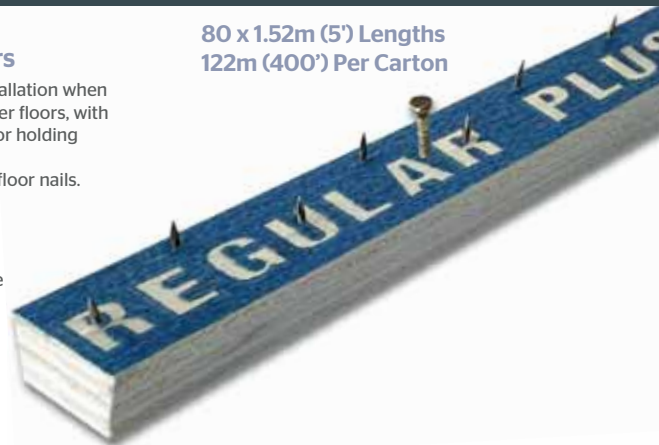

Medium Pin 4.8mm (3/16")

REGPLUS-WP

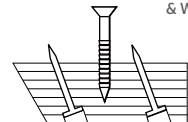

Medium Pin & Wood Nail

REGPLUS-DP

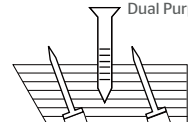

Medium Pin & Dual Purpose Nail

## GRIPPER FIXINGS

### NAILS

Concrete and Ring Shank Nails for fixings



Item No.	Description	Pack Size
6762P	Concrete Nails - 18mm	5 x 1kg Tubs
6763P	Concrete Nails - 25mm - (1")	4 x 1kg Tubs
6772P	Ring Shank Nails - 18mm	4 x 1kg Tubs

## GRIPPER SHEARS

Ideal for fast, accurate cutting of wooden gripper to fit the contours of any room. provides a firm base on which to rest the gripper when cutting. High quality steel blades and moulded, plastic coated handles for a firm comfortable grip.

R10108  
Strip Cutter



R570  
Smoothedge Shears



## GRIPPERODS® CONTRACT GRIPPER

A specialist gripper for particularly heavy stretch installations. Manufactured in the UK from 6mm 5ply plywood, It is 42mm wide and has 126 carpet holding pins in 3 rows compared to the 2 rows in other gripper specifications. It is available in both medium and long pin heights with no floor nails. This allows the fitter to install by nailing or adhering the gripper to the floor, depending on the installation.

50 x 1.52m (5') Lengths  
76m (250') Per Carton



C210



Long Pin & No Nail

C110



Medium Pin & No Nail

**GRIPPERRODS® WOOD NEAT EDGE (BLIND GRIPPER)**

This gripper enables the installer to create the perfect finished appearance around the wall for single and double-stick installations. Manufactured in the UK from 5 ply plywood with dual purpose pre-nails, but no pins.

**100 x 1.52m (5') Lengths**  
**152m (500') Per Carton**



**3370**

No Pins & Dual Purpose Nail

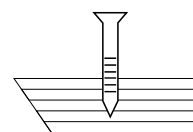

**GRIPPERRODS® FLOORWORKS GRIPPER (FOR FLAT AREAS)**

Designed for use with underlay to give the best finished appearance to the installation and the best wear characteristics. Microplast tape top surface and dual purpose floor pre-nails for fast, good finish, tension fit installations on underlay. The recommended installation method for fitting underlay with felt back carpets.

**100 x 1.52m (5') Lengths**  
**152m (500') Per Carton**



**FW007**

Microplast Tape & Dual Purpose Nail

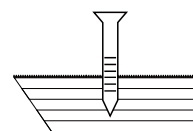

**GRIPPERRODS® FLOORWORKS GRIPPER (FOR STAIRS)**

Specially designed for use on stairs. A combination of Microplast tape and standard profile gripper pins. The pins prevent the aggressive Microplast tape from gripping the felt back prematurely prior to the carpet being tucked into the stair gully. Once tucked in, the pins combine with the Microplast tape to give the high holding strength required on stairs. The recommended installation method for fitting underlay with felt back carpets.

**100 x 1.52m (5') Lengths**  
**152m (500') Per Carton**

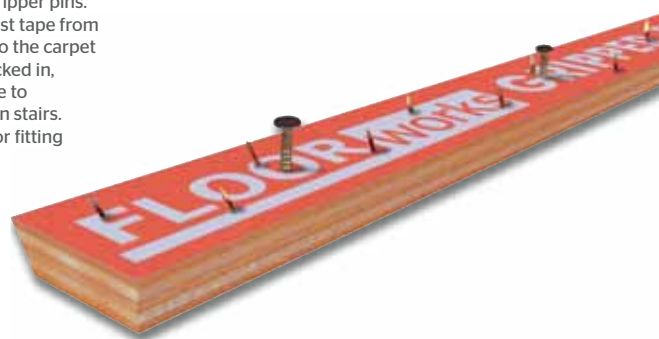

**FW008**

Microplast Tape & Wood Nail

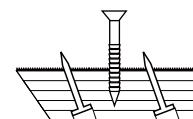

**CUSTOM PRINTED GRIPPER**

We can supply gripper printed to your own personal requirements. Available in the below specifications in **medium pin only**. Please contact Interfloor Sales for more information.

**100 x 1.52m (5') Lengths 152.3m (500') Per Carton**

- Stick Down Gripper    24.3mm wide    **2110**
- Wood Floor Gripper    24.3mm wide    **2120**
- Concrete Floor Gripper 24.3mm wide    **2140**

- Stick Down Gripper    22.0mm wide    **3110**
- Wood Floor Gripper    22.0mm wide    **3120**
- Concrete Floor Gripper 22.0mm wide    **3140**
- Dual Floor Gripper    22.0mm wide    **3170**





***Gripperods***<sup>®</sup>

Premier  
FLOOR EDGINGS

The perfect  
finishing touch

Gripperods Premier Floor Edgings provide an exceptional finish to premium flooring installations. Available in five finishes - brushed steel nickel, chrome, brushed black, brushed Pewter and Light Bronze - our premier edgings are ideal for modern, luxurious interiors.

Premier edgings are perfect for joining floors of different materials, different heights and between doorways.

## COVERSTRIP

Premium quality self-adhesive for use with most flooring types of equal levels.



**STICK  
DOWN**

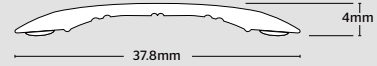

2.70m x 5 Per Tube		0.9m x 15 Per Carton	
BRUSHED STEEL NICKEL:	<b>M13.9BSA</b>	BRUSHED STEEL NICKEL:	<b>M13.3BSA</b>
CHROME:	<b>M13.9CHA</b>	CHROME:	<b>M13.3CHA</b>
BRUSHED BLACK:	<b>M13.9BBA</b>	BRUSHED BLACK:	<b>M13.3BBA</b>
BRUSHED PEWTER:	<b>M13.9PWA</b>	BRUSHED PEWTER:	<b>M13.3PWA</b>
BRUSHED LIGHT BRONZE:	<b>M13.9LBA</b>	BRUSHED LIGHT BRONZE:	<b>M13.3LBA</b>

## SINGLE EDGE

Used for joining carpet to vinyl or other hard surfaces.

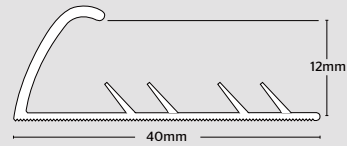

2.70m x 5 Per Tube		0.9m x 15 Per Carton	
BRUSHED STEEL NICKEL:	<b>M26.9BS</b>	BRUSHED STEEL NICKEL:	<b>M26.3BS</b>
CHROME:	<b>M26.9CH</b>	CHROME:	<b>M26.3CH</b>
BRUSHED BLACK:	<b>M26.9BB</b>	BRUSHED BLACK:	<b>M26.3BB</b>
BRUSHED PEWTER:	<b>M26.9PW</b>	BRUSHED PEWTER:	<b>M26.3PW</b>
BRUSHED LIGHT BRONZE:	<b>M26.9LB</b>	BRUSHED LIGHT BRONZE:	<b>M26.3LB</b>

## DUAL EDGE

Used for joining carpet to carpet at doorways.

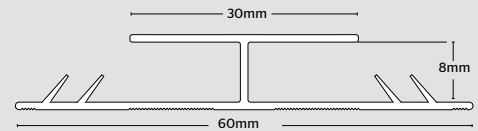

2.70m x 5 Per Tube		0.9m x 15 Per Carton	
BRUSHED STEEL NICKEL:	<b>M36.9BS</b>	BRUSHED STEEL NICKEL:	<b>M36.3BS</b>
CHROME:	<b>M36.9CH</b>	CHROME:	<b>M36.3CH</b>
BRUSHED BLACK:	<b>M36.9BB</b>	BRUSHED BLACK:	<b>M36.3BB</b>
BRUSHED PEWTER:	<b>M36.9PW</b>	BRUSHED PEWTER:	<b>M36.3PW</b>
BRUSHED LIGHT BRONZE:	<b>M36.9LB</b>	BRUSHED LIGHT BRONZE:	<b>M36.3LB</b>

## RAMP EDGE

Premium quality, gives a smooth transition down to resilient floorings.



**STICK  
DOWN**

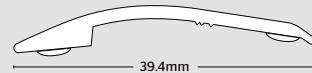

2.70m x 5 Per Tube		<b>RAMP EDGE MEDIUM</b>
BRUSHED STEEL NICKEL:	<b>M08.9BSA</b>	
CHROME:	<b>M08.9CHA</b>	
BRUSHED BLACK:	<b>M08.9BBA</b>	
BRUSHED PEWTER:	<b>M08.9PWA</b>	
BRUSHED LIGHT BRONZE:	<b>M08.9LBA</b>	



**STICK  
DOWN**



2.70m x 5 Per Tube		<b>RAMP EDGE SMALL</b>
BRUSHED STEEL NICKEL:	<b>M09.9BSA</b>	
CHROME:	<b>M09.9CHA</b>	
BRUSHED BLACK:	<b>M09.9BBA</b>	
BRUSHED PEWTER:	<b>M09.9PWA</b>	
BRUSHED LIGHT BRONZE:	<b>M09.9LBA</b>	

## ZIG ZAG

Provides a neat transition between laminate/hard flooring and adjacent stretch carpet installation.

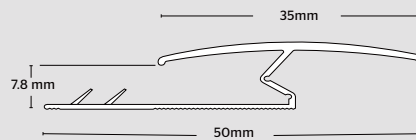

2.70m x 5 Per Tube		0.9m x 15 Per Carton	
BRUSHED STEEL NICKEL:	<b>M38.9BS</b>	BRUSHED STEEL NICKEL:	<b>M38.3BS</b>
CHROME:	<b>M38.9CH</b>	CHROME:	<b>M38.3CH</b>
BRUSHED BLACK:	<b>M38.9BB</b>	BRUSHED BLACK:	<b>M38.3BB</b>
BRUSHED PEWTER:	<b>M38.9PW</b>	BRUSHED PEWTER:	<b>M38.3PW</b>
BRUSHED LIGHT BRONZE:	<b>M38.9LB</b>	BRUSHED LIGHT BRONZE:	<b>M38.3LB</b>

## NOSING 9MM

Ideal for use on wood / laminate flooring where a self adhesive fixing is required.



**STICK DOWN**

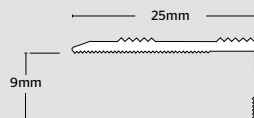

2.70m x 5 Per Tube	
BRUSHED STEEL NICKEL:	<b>M74.9BSA</b>
BRUSHED BLACK:	<b>M74.9BBA</b>
BRUSHED PEWTER:	<b>M74.9PWA</b>
BRUSHED LIGHT BRONZE:	<b>M74.9LBA</b>

# Gripperrods® Premier

## High-quality point of sale

A counter-top point of sale display is available for use in-store along with a handy estimator roll, perfect for when visiting customers in their home.

Contact the Interfloorsales office on **01706 238810**



Estimator Roll

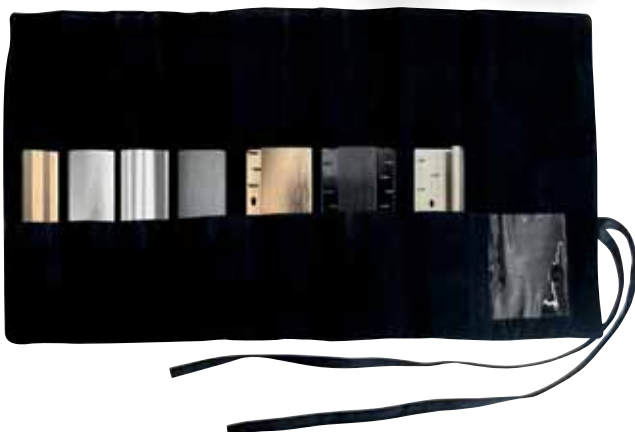

185mm x 440mm Counter-top display

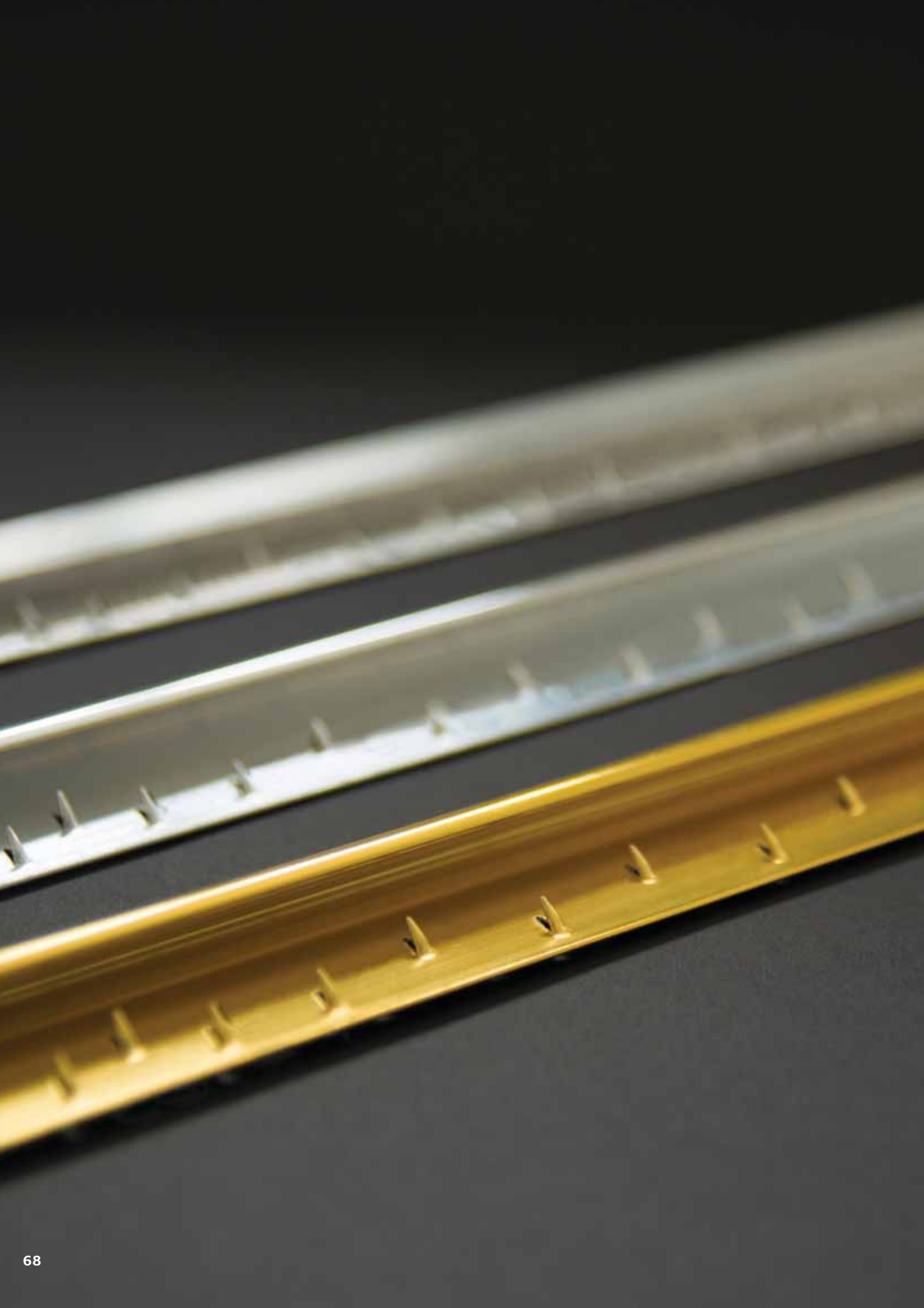



**Gripperrods®**

## CARPET & VINYL FLOOR EDGINGS

For a clean transition  
between spaces

Edgings give floor fittings a professional touch. Our floor edgings offer solutions to suit all types of floor including laminate, wooden and tiled. Our metal edgings are available in polished aluminium, anodised gold, matt gold, matt silver and Oak effect . We offer products that are also suitable for joining two flooring types of different heights or level. The improved range of self-adhesive edgings provides greater flexibility for the installer.

## VINYL EDGE - SMALL/MEDIUM

For resilient floor coverings. High lustre finish in both gold anodised and polished aluminium. Includes fixings.

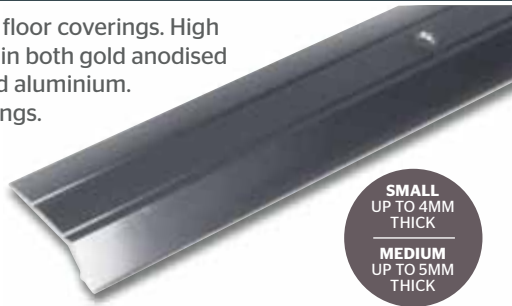

**SMALL**  
UP TO 4MM THICK

**MEDIUM**  
UP TO 5MM THICK

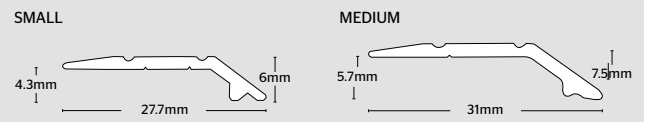

2.70m x 15 Per Tube		0.9m x 45 Per Carton	
ALUMINIUM (SMALL):	<b>MO2.9A</b>	ALUMINIUM (SMALL):	<b>MO2.3A</b>
GOLD (SMALL):	<b>MO2.9G</b>	GOLD (SMALL):	<b>MO2.3G</b>
ALUMINIUM (MEDIUM):	<b>MO3.9A</b>	ALUMINIUM (MEDIUM):	<b>MO3.3A</b>
GOLD (MEDIUM):	<b>MO3.9G</b>	GOLD (MEDIUM):	<b>MO3.3G</b>

## VINYL COVERSTRIP

Conceals and protects joints between all grades and thicknesses of resilient floor coverings. High lustre finish in both gold anodised and polished aluminium. Includes fixings.

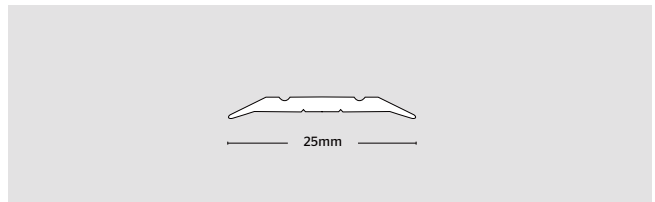
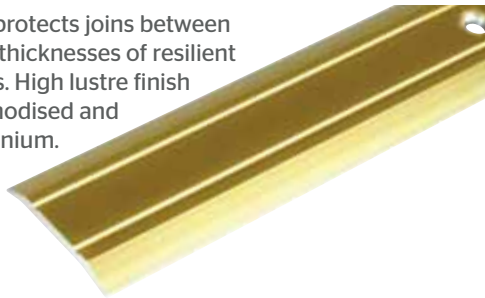

2.70m x 15 Per Tube		0.9m x 45 Per Carton	
ALUMINIUM:	<b>MO1.9A</b>	ALUMINIUM:	<b>MO1.3A</b>
GOLD:	<b>MO1.9G</b>		

## CARPET COVERSTRIP

The angled ribs extruded on the underside lock into the carpet pile and draw the two edges together. Includes fixings.

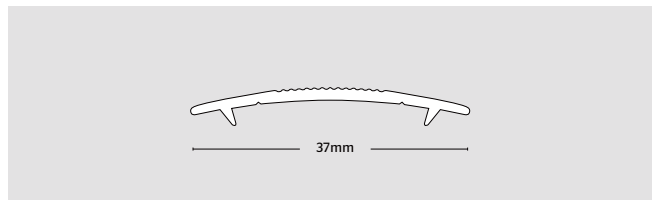

2.70m x 15 Per Tube		0.9m x 45 Per Carton	
ALUMINIUM:	<b>M10.9A</b>	ALUMINIUM:	<b>M10.3A</b>
GOLD:	<b>M10.9G</b>	GOLD:	<b>M10.3G</b>

## CONTRACT COVERSTRIP

Designed for use with low pile carpets, carpet tiles or resilient floor coverings. High lustre finish in both gold anodised and polished aluminium. Includes fixings.

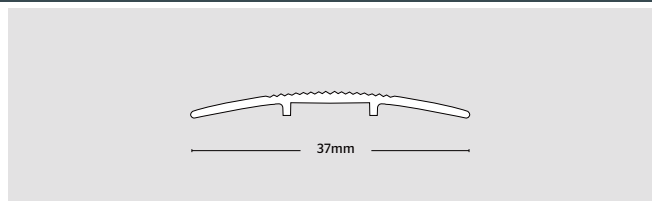

2.70m x 15 Per Tube		0.9m x 45 Per Carton	
ALUMINIUM:	<b>M11.9A</b>	ALUMINIUM:	<b>M11.3A</b>
GOLD:	<b>M11.9G</b>	GOLD:	<b>M11.3G</b>

## EXTRA WIDE COVERSTRIP

The widest Coverstrip in the range to cover difficult joints between any floor coverings. Includes fixings.

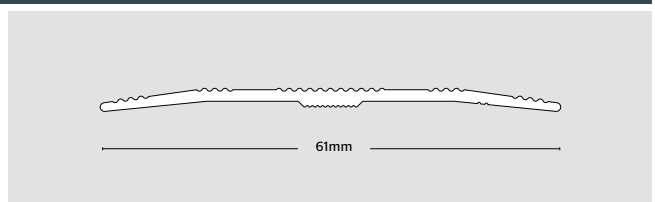

2.70m x 15 Per Tube		0.9m x 45 Per Carton	
ALUMINIUM:	<b>M12.9A</b>	ALUMINIUM:	<b>M12.3A</b>
GOLD:	<b>M12.9G</b>	GOLD:	<b>M12.3G</b>

**SINGLE EDGE | CARPET EDGE - NARROW**

High lustre finishes in both gold anodised and polished aluminium. The lighter version of Carpet Edge - Standard.

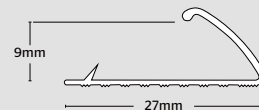
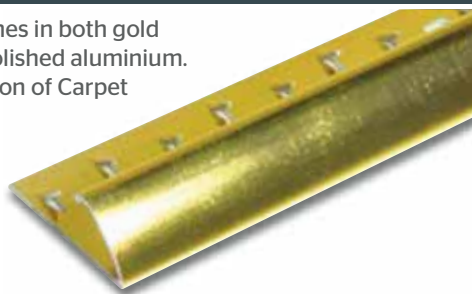

2.70m x 15 Per Tube		0.9m x 45 Per Carton	
ALUMINIUM:	<b>M29.9A</b>	ALUMINIUM:	<b>M29.3A</b>
GOLD:	<b>M29.9G</b>	GOLD:	<b>M29.3G</b>

**SINGLE EDGE | CARPET EDGE - STANDARD**

High lustre finishes in both gold anodised and polished aluminium.

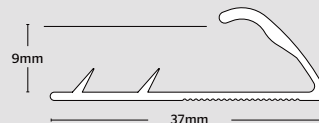

2.70m x 15 Per Tube		0.9m x 45 Per Carton	
ALUMINIUM:	<b>M20.9A</b>	ALUMINIUM:	<b>M20.3A</b>
GOLD:	<b>M20.9G</b>	GOLD:	<b>M20.3G</b>

**SINGLE EDGE | CARPET EDGE - FLUTED**

As Carpet Edge Standard, but with fluting to give a rich tone against the carpet.

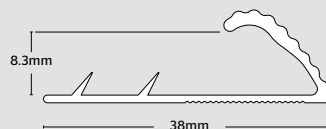

2.70m x 15 Per Tube	
ALUMINIUM:	<b>M22.9A</b>
GOLD:	<b>M22.9G</b>

**SINGLE EDGE | CARPET EDGE - HEAVY DUTY**

Heavy duty version of the carpet edge with wider base for use with thicker carpets.

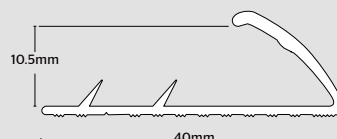

2.70m x 15 Per Tube	
ALUMINIUM:	<b>M28.9A</b>
GOLD:	<b>M28.9G</b>

**SINGLE EDGE | CARPET EDGE - HEAVY DUTY RAISED BASE**

This heavy duty version of the Carpet Edge is designed to secure the heavier grade of contract carpet. The wider base and the high lustre gold anodised finish gives a 'quality' look to the flooring installation.

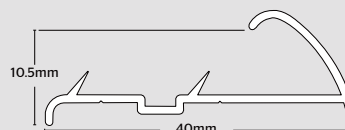

2.70m x 15 Per Tube	
ALUMINIUM:	<b>M21.9A</b>
GOLD:	<b>M21.9G</b>

## SINGLE EDGE | CARPET EDGE - CARPET TILE EDGING

Specifically designed to protect the exposed edges of loose laid carpet tiles where no wall line exists.

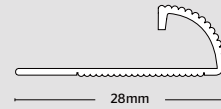
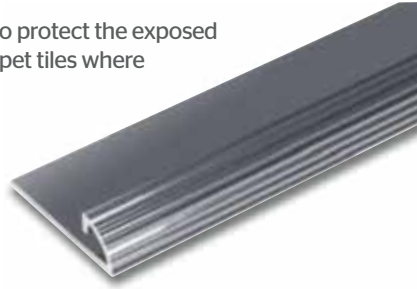

2.70m x 15 Per Tube

ALUMINIUM: **M25.9A**

## DUALGRIP - STANDARD

The industry standard with a full 20mm top and 50mm base, available in high lustre finishes in both gold anodised and polished aluminium.

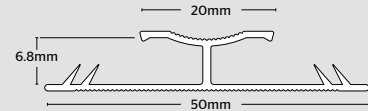

2.70m x 15 Per Tube

ALUMINIUM: **M30.9A**

GOLD: **M30.9G**

0.9m x 45 Per Carton

ALUMINIUM: **M30.3A**

GOLD: **M30.3G**

## DUALGRIP - RAISED BASE

The best type of double edge for carpets fitted with underlay, which is cut to butt up to the lips of the profile giving the smoothest transition to the finished installation.

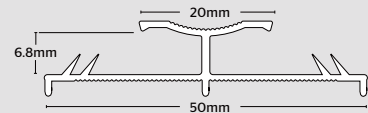
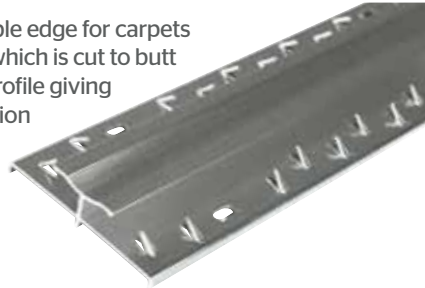

2.70m x 15 Per Tube

ALUMINIUM: **M37.9A**

## DUALGRIP - HEAVY DUTY

Heavy duty version of M30 with 28mm top and 62mm base.

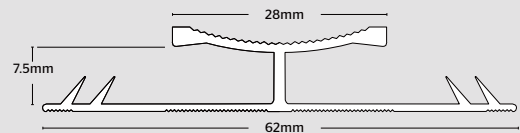
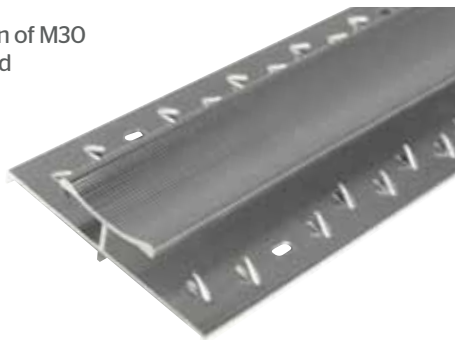

2.70m x 9 Per Tube

ALUMINIUM: **M31.9A**

GOLD: **M31.9G**

0.9m x 27 Per Carton

ALUMINIUM: **M31.3A**

GOLD: **M31.3G**

## DUALGRIP - HEAVY DUTY RAISED BASE

This heavy duty version of the raised base Dualgrip is designed to secure the heavier grade of contract carpet. Recommended for the best installations. The wider top and the high lustre gold anodised finish gives that 'quality' look that can't be achieved using the standard product.

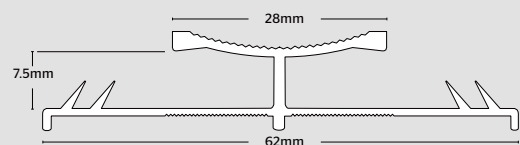
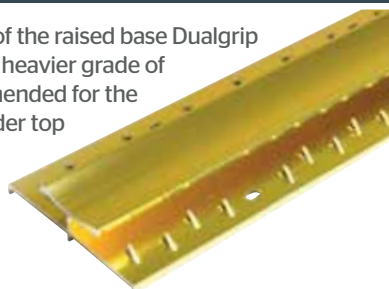

2.70m x 9 Per Tube

ALUMINIUM: **M32.9A**

GOLD: **M32.9G**

0.9m x 27 Per Carton

ALUMINIUM: **M32.3A**

GOLD: **M32.3G**

**SINGLE EDGE | SQUARE EDGE**

Can be used for a variety of installations, as a carpet capping or finishing to open plan areas, easily mitred to form an access panel. Finished with a fine ribbed design which will keep its appearance even when subjected to heavy traffic.

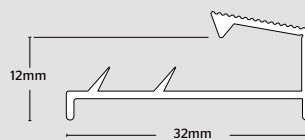

2.70m x 15 Per Tube

ALUMINIUM: **M72.9A**  
GOLD: **M72.9G**

**KARPETEDGE**

Used in conjunction with carpet gripper, Karpetedge provides a perfect, rolled edge finish to the carpet on flush surfaces in low traffic areas. It is ideal for providing a finish to open landings or covered skirtings.

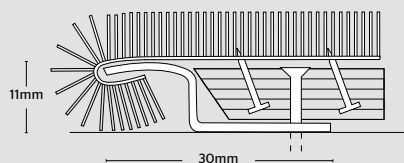

1.21m x 10 Per Tube

ALUMINIUM: **7011**

**ZIG ZAG® - 9MM**

The 9mm Zig Zag® gives a neat transition between laminate/hard flooring and adjacent stretch carpet installation.

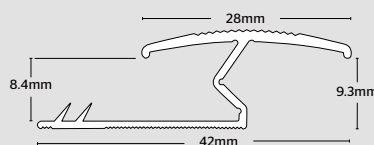

2.70m x 15 Per Tube

ALUMINIUM: **M34.9A**  
GOLD: **M34.9G**  
MATT SILVER: **M34.9AM**

0.9m x 45 Per Carton

ALUMINIUM: **M34.3A**  
GOLD: **M34.3G**

**ZIG ZAG® - 15MM**

The 15mm Zig Zag® gives a neat transition between laminate/hard flooring and adjacent stretch carpet installation.

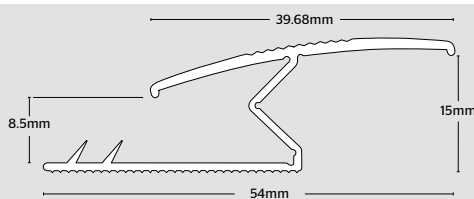
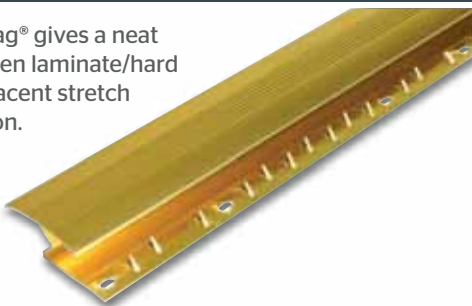

2.70m x 10 Per Tube

ALUMINIUM: **M33.9A**  
GOLD: **M33.9G**

**ZIG ZAG® - 20MM**

Zig Zag® 20mm without teeth. Gives a neat transition between two sections of hard flooring.



**FITTING ZIG ZAG®**

Zig Zag® should be lightly dressed down using a rubber mallet after fitting, to ensure a snug fit to the edges of both floor coverings.

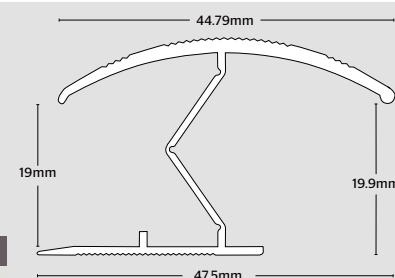

2.70m x 10 Per Tube

ALUMINIUM: **M35.9A**

## FINISHING EDGES - ANGLE SECTION - SMALL

For applications requiring a right angled finish. Plain one edge, ribbed on the other. Undrilled.

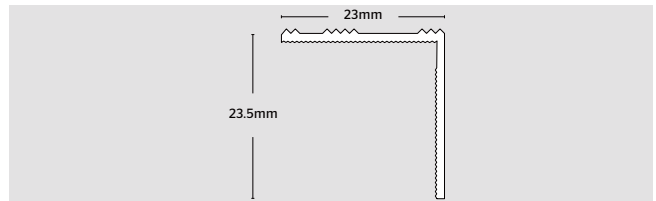
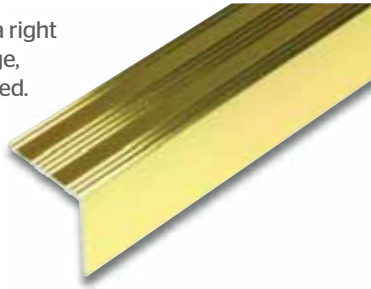

2.70m x 15 Per Tube

ALUMINIUM: **M70.9A**  
GOLD: **M70.9G**

## FINISHING EDGES - MATWELL EDGING

For any application where a right angled edging is required and offering a higher quality finish than the small angle section. Particularly suitable for mat wells, where the ribbed surface provides a non-slip finish to the installation. Undrilled.

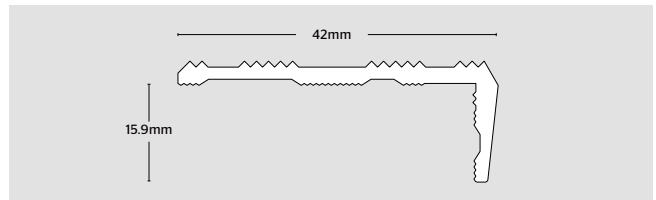

2.70m x 15 Per Tube

ALUMINIUM: **M71.9A**  
GOLD: **M71.9G**

## STAIR NOSING - WITH SEPARATE INSERT

For any application where a right angled edging is required and offering a higher quality finish than the small angle section. Particularly suitable for mat wells, where the ribbed surface provides a non-slip finish to the installation. Undrilled.

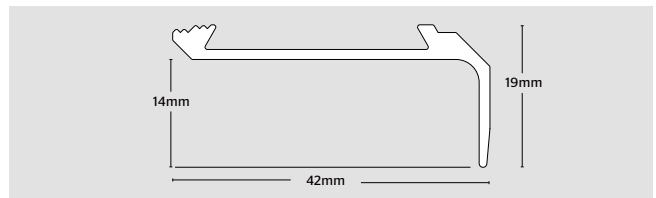

2.70m x 10 Per Tube

ALUMINIUM: **19419**

## FIXING SCREWS

Zinc and Brass plated screws for fixings

Item No.	Description	Pack Size
6791P	Zinc Screws - 25mm - (1")	4 x 1kg Tubs
6793P	Brass plated Screws - 25mm - (1")	4 x 1kg Tubs



# SLIMLINE STAIR NOSINGS



Our range of slimline aluminium Stair Nosings profiles include black PVC anti slip inserts, and are pre-drilled with screws and PVC pips (to cover the screw holes).



## SLIMLINE ALUMINIUM SINGLE SQUARE NOSE

Ideal for stairs or steps with vinyl linoleum and needle punch carpets.

2.44m x 10 Per Tube

BLACK (PVC anti slip insert) **W01244PC**

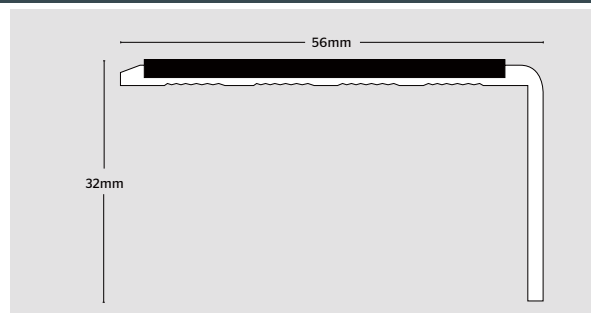

## SLIMLINE ALUMINIUM BULL NOSE

Ideal on existing steps with a bullnose or rounded edge with vinyl linoleum and needle punch carpets.

2.44m x 10 Per Tube

BLACK (PVC anti slip insert) **W06244PC**



## SLIMLINE ALUMINIUM SINGLE RAKED BACK

Ideal on stairs or steps that slop backwards with vinyl linoleum and needle punch carpets.

2.44m x 10 Per Tube

BLACK (PVC anti slip insert) **W07244PC**

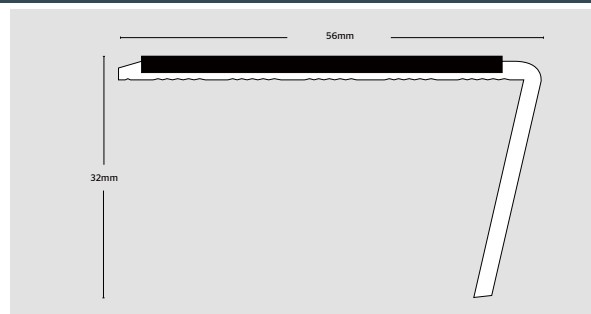

**ANGLE EDGE - 8MM**

The 9mm Zig Zag® gives a neat transition between laminate/hard flooring and adjacent stretch carpet installation.

Includes Screws and fixings.

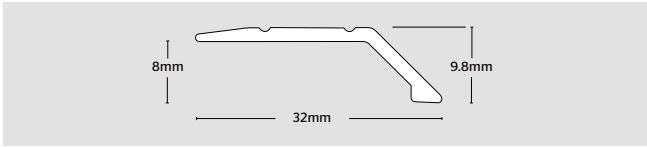

2.70m x 15 Per Tube  
ALUMINIUM: **M04.9A**

**ANGLE EDGE - 8MM - SELF-ADHESIVE**

Gives a smooth transition down to resilient floorings.

STICK DOWN

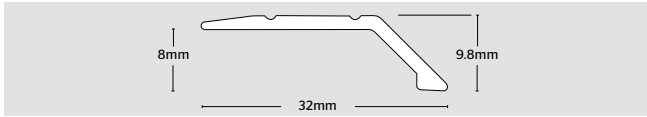

2.70m x 10 Per Tube		0.9m x 30 Per Carton	
ALUMINIUM:	<b>M04.9ASD</b>	ALUMINIUM:	<b>M04.3ASD</b>
GOLD:	<b>M04.9GSD</b>	GOLD:	<b>M04.3GSD</b>
MATT SILVER:	<b>M04.9AMA</b>		
MATT GOLD:	<b>M04.9GMA</b>		
OAK:	<b>M04.9WOA</b>		

**ANGLE EDGE - 14MM - SELF-ADHESIVE**

14mm self-adhesive version of the Angle Edge.

STICK DOWN

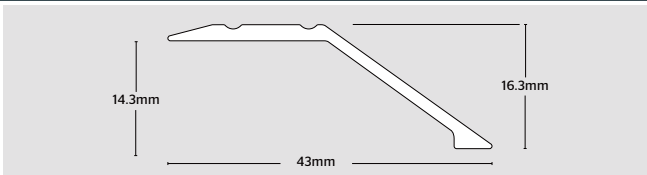

2.70m x 10 Per Tube  
MATT SILVER: **M05.9AMA**  
MATT GOLD: **M05.9GMA**  
OAK: **M05.9WOA**

**ANGLE EDGE - 22MM - SELF-ADHESIVE**

22mm self-adhesive version of the Angle Edge.

STICK DOWN

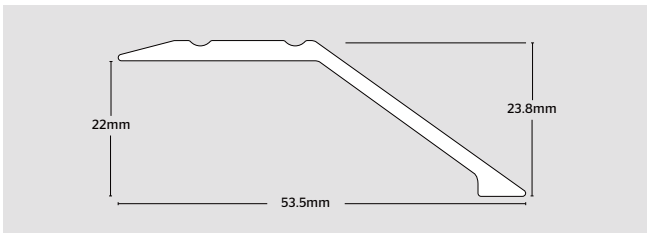

2.70m x 10 Per Tube  
MATT SILVER: **M06.9AMA**

**EURO COVERSTRIP - 38.5MM - SELF-ADHESIVE**

High quality self-adhesive coverstrip for use with most flooring types of equal levels.

**STICK DOWN**

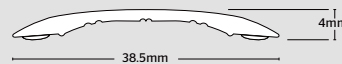

2.70m x 10 Per Tube		0.9m x 30 Per Carton	
ALUMINIUM:	<b>M13.9ASD</b>	ALUMINIUM:	<b>M13.3ASD</b>
GOLD:	<b>M13.9GSD</b>	GOLD:	<b>M13.3GSD</b>
MATT SILVER:	<b>M13.9AMA</b>	MATT SILVER:	<b>M13.3AMA</b>
MATT GOLD:	<b>M13.9GMA</b>		
OAK:	<b>M13.9WOA</b>		

2.70m x 5 Per Tube		0.9m x 15 Per Carton	
BRUSHED STEEL NICKEL:	<b>M13.9BSA</b>	BRUSHED STEEL NICKEL:	<b>M13.3BSA</b>
CHROME:	<b>M13.9CHA</b>	CHROME:	<b>M13.3CHA</b>
BRUSHED BLACK:	<b>M13.9BBA</b>	BRUSHED BLACK:	<b>M13.3BBA</b>
BRUSHED PEWTER:	<b>M13.9PWA</b>	BRUSHED PEWTER:	<b>M13.3PWA</b>
BRUSHED LIGHT BRONZE:	<b>M13.9LBA</b>	BRUSHED LIGHT BRONZE:	<b>M13.3LBA</b>

**ZIG ZAG® - 9MM**

Gives a smooth transition between hard flooring and an adjacent stretch carpet installation. Top of section should be lightly dressed down using a rubber mallet after fitting, to ensure a snug fit to edges of both floor coverings.

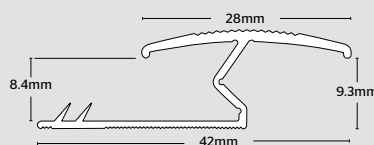

2.70m x 15 Per Tube		0.9m x 45 Per Carton	
ALUMINIUM:	<b>M34.9A</b>	ALUMINIUM:	<b>M34.3A</b>
GOLD:	<b>M34.9G</b>	GOLD:	<b>M34.3G</b>
MATT SILVER:	<b>M34.9AM</b>		

**ZIG ZAG® - 15MM**

15mm version of 9mm Zig Zag® section. Gives a smooth transition between a hard flooring and an adjacent stretch carpet installation. Top of section should be lightly dressed down using a rubber mallet after fitting, to ensure a snug fit to edges of both floor coverings.

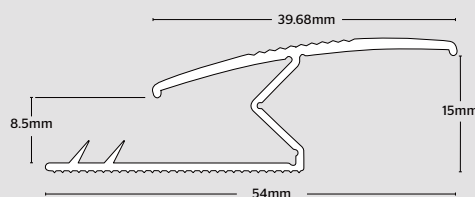

2.70m x 10 Per Tube	
ALUMINIUM:	<b>M33.9A</b>
GOLD:	<b>M33.9G</b>

**ZIG ZAG® - 20MM**

Zig Zag® 20mm without teeth. Gives a smooth transition between two sections of hard flooring. Top of section should be lightly dressed down using a rubber mallet after fitting, to ensure a snug fit to edges of both floor coverings.

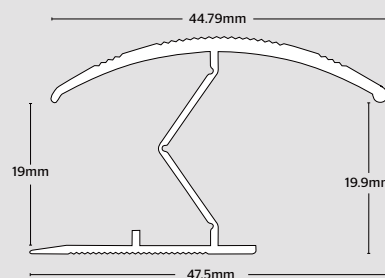

2.70m x 10 Per Tube	
ALUMINIUM:	<b>M35.9A</b>

## NOSINGS - 9MM SELF-ADHESIVE

Ideal for use on wood / laminate flooring where a self-adhesive fixing is required.

STICK  
DOWN

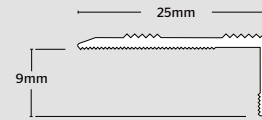

2.70m x 10 Per Tube

MATT SILVER:	<b>M74.9AMA</b>
MATT GOLD:	<b>M74.9GMA</b>
OAK:	<b>M74.9WOA</b>

2.70m x 5 Per Tube

BRUSHED STEEL NICKEL:	<b>M74.9BSA</b>
BRUSHED BLACK:	<b>M74.9BBA</b>
BRUSHED PEWTER:	<b>M74.9PWA</b>
BRUSHED LIGHT BRONZE:	<b>M74.9LBA</b>

## NOSINGS - 15MM SELF-ADHESIVE

15mm version of the 9mm nosing.  
Ideal for use on wood / laminate flooring where a self-adhesive fixing is required.

STICK  
DOWN

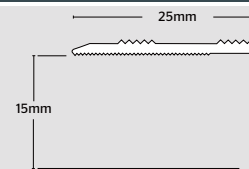
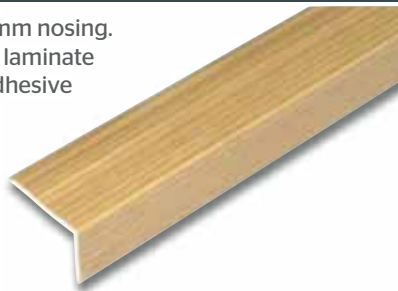

2.70m x 10 Per Tube

MATT SILVER:	<b>M75.9AMA</b>
MATT GOLD:	<b>M75.9GMA</b>
OAK:	<b>M75.9WOA</b>

## NOSINGS - 20MM SELF-ADHESIVE

20mm version of the 9mm nosing.  
Ideal for use on wood / laminate flooring where a self-adhesive fixing is required.

STICK  
DOWN

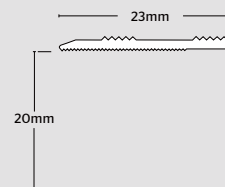

2.70m x 10 Per Tube

MATT SILVER:	<b>M76.9AMA</b>
OAK:	<b>M76.9WOA</b>

## NOSINGS - 23MM SELF-ADHESIVE

Heavy duty version of the 20mm nosing, with slight bull nose.

STICK  
DOWN

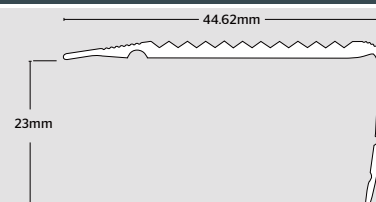
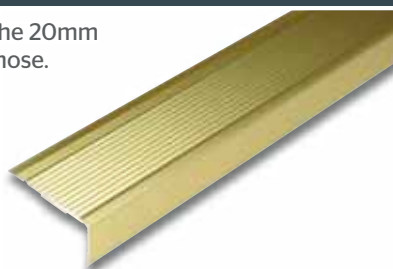

2.70m x 10 Per Tube

MATT SILVER:	<b>M78.9AMA</b>
MATT GOLD:	<b>M78.9GMA</b>

**SQUAREEDGE - 8.5MM**

To give a neat square edge against which to butt other floor coverings. Also effective for finishing around French windows or raised thresholds. Fits over edge of laminate. No screws or fixings required.

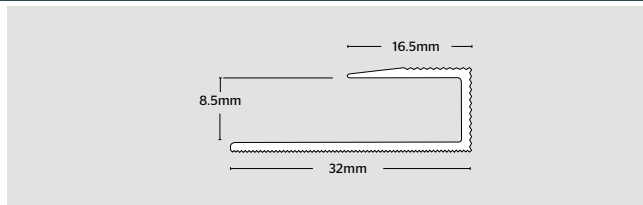

2.70m x 10 Per Tube  
**MATT SILVER: M85.9AM**



**PROTECTIVE FILM AND FIXINGS**

Gripperods® metals are provided with a branded, removable protective film for the showface of the edging or sleeved. Where necessary each product has fixings provided. Extra fixings are available below

**FIXING SCREWS**

Zinc and Brass plated screws for fixings

Item No.	Description	Pack Size
6791P	Zinc Screws - 25mm - (1")	4 x 1kg Tubs
6793P	Brass plated Screws - 25mm - (1")	4 x 1kg Tubs



**Point of Sale merchandise available**

Consumers want to see first-hand what they're buying. We can support your metal edging sales with attractive counter display boards presenting sections of standard edgings and nosings in various finishes.

# ADHESIVES & TAPES

## Creating a strong underlay foundation

Our range of tape and adhesives provides strength and resilience to underlay installations for a long-lasting finish. This collection of products offers everything for the professional fitter with solutions that match all flooring types.



STK950	DESCRIPTION	SUITABLE SUB-FLOOR USAGE	SPECIFICATION AND STORAGE
<p>Double-stick Tackifier Adhesive</p> 	<p>STK950 is a permanently tacky water based acrylic dispersion adhesive which is solvent free and has a low odour. It has been designed to provide a limited bond for Tredaire and Duralay Double Stick underlays.</p> <p>STK950 is packaged in a rectangular bucket for ease of application when applying with a roller.</p>	<ul style="list-style-type: none"> <li>Concrete.</li> <li>Flooring grade hardboard.</li> <li>Plywood.</li> <li>Chipboard.</li> <li>Sand/cement screed.</li> <li>Proprietary good quality self-smoothing underlayments.</li> </ul> <p>Asphalt and surface membranes should be treated with at least a 3mm coating of smoothing compound before applying adhesive.</p>	<p><b>Pack Size:</b> 15kg  <b>Coverage:</b> Approximately 4-9m<sup>2</sup> per kg, depending on the porosity of the substrate and thickness of the adhesive film.</p> <p><b>Storage:</b> 12 months if stored between 5°C (41°F) to 30°C (86°F) in a cool, dry area, in original unopened containers. Protect from frost.</p>
<p>Double-stick Carpet Adhesive</p> 	<p>STK900 is a solvent free, versatile, water based synthetic acrylic adhesive which is easy to trowel and is non staining. This product has been specifically formulated for use with Double-stick systems where a long open time is required and is particularly suitable in warm climates.</p> <p>STK900 is suitable for hessian, Action back, needle punch, rubber, gel &amp; latex backed carpets, non-plasticised vinyl floor coverings &amp; cushioned vinyl. <b>STK900 is not suitable for use on plasticised PVC.</b></p>	<ul style="list-style-type: none"> <li>Concrete.</li> <li>Flooring grade hardboard.</li> <li>Plywood.</li> <li>Chipboard.</li> <li>Sand/cement screed.</li> <li>Proprietary good quality self-smoothing underlayments.</li> </ul> <p>Asphalt and surface membranes should be treated with at least a 3mm coating of smoothing compound before applying adhesive.</p>	<p><b>Pack Size:</b> 15kg  <b>Coverage:</b> Approximately 2-3m<sup>2</sup> per kg, depending on the porosity of the substrate and thickness of the adhesive film.</p> <p><b>Storage:</b> 12 months if stored between 5°C (41°F) to 30°C (86°F) in a cool, dry area, in original unopened containers. Protect from frost.</p>
<p>Fast Grab Multi-Purpose Flooring Adhesive</p> 	<p>STK300 is a versatile, water based synthetic acrylic multi-purpose adhesive which has exceptional bond strength, fast grab, is easy to trowel and is non staining.</p> <p>STK300 is suitable for hessian, Action back, needle punch, rubber, gel &amp; latex backed carpets, non-plasticised vinyl floor coverings &amp; cushioned vinyl. <b>STK300 is not suitable for use on plasticised PVC.</b></p>	<ul style="list-style-type: none"> <li>Concrete.</li> <li>Flooring grade hardboard.</li> <li>Plywood.</li> <li>Chipboard.</li> <li>Sand/cement screed.</li> <li>Proprietary good quality self-smoothing underlayments.</li> </ul> <p>Asphalt and surface membranes should be treated with at least a 3mm coating of smoothing compound before applying adhesive.</p>	<p><b>Pack Size:</b> 15kg  <b>Coverage:</b> Approximately 2-3m<sup>2</sup> per kg, depending on the porosity of the substrate and thickness of the adhesive film.</p> <p><b>Storage:</b> 12 months if stored between 5°C (41°F) to 30°C (86°F) in a cool, dry area, in original unopened containers. Protect from frost.</p>
<p>Very Low Emission, Acrylic Flooring Adhesive</p> 	<p>STK100 is a solvent free high performance water based acrylic adhesive which has very good bond strength and very low emissions.</p> <p>STK100 is suitable for plasticized vinyl floor coverings (including tiles), carpets with PVC, PU, Latex, Textile and high density foam backings.</p>	<ul style="list-style-type: none"> <li>Concrete.</li> <li>Flooring grade hardboard.</li> <li>Plywood.</li> <li>Chipboard.</li> <li>Sand/cement screed.</li> <li>Proprietary good quality self-smoothing underlayments.</li> </ul> <p>Asphalt and surface membranes should be treated with at least a 3mm coating of smoothing compound before applying adhesive.</p>	<p><b>Pack Size:</b> 15kg  <b>Coverage:</b> Approximately 3-4m<sup>2</sup> per kg, depending on the porosity of the substrate and thickness of the adhesive film.</p> <p><b>Storage:</b> 12 months if stored between 5°C (41°F) to 30°C (86°F) in a cool, dry area, in original unopened containers. Protect from frost.</p>

## Need Advice on Fitting?

You will find lots of advice and videos on the Interfloor YouTube channel, search for Interfloor Ltd or use the QR code here:



## PREMIER GOLD



A contract grade double-sided tape with a very heavy coating of aggressive synthetic rubber resin adhesive and easily tearable woven cotton carrier, providing high initial tack and subsequent bond strength. Flexible and conformable to all floor surfaces. Excellent gap fill and adhesion to heavily textured carpet backings. Suitable for installing rubber, foam-backed carpets, traditional, polyurethane and woven polypropylene backings.

**50mm x 50m / 5 Per Carton: 6492P**

## PREMIER BRONZE



A medium duty carpet tape with a thin film carrier and outstanding tack and tension. Suitable for flat, even subfloors. No ridges or tramlines on thin floor coverings. Suitable for use with carpets and carpet tiles.

**50mm x 50m / 5 Per Carton: 6494P**

## PREMIER SILVER



A heavy domestic grade tape with a high coating of synthetic rubber resin adhesive on a woven cotton scrim and siliconised kraft paper liner which can be easily removed. Flexible and conformable to all floor surfaces. Good gap fill and adhesion to textured surfaces. Suitable for foam-backed and polyurethane backed carpets.

**50mm x 50m / 5 Per Carton: 6493P**

## PREMIER GREEN PMR



A high technology product formulated from a special adhesive system to withstand the rigours of plasticiser attack. Specified by many manufacturers of PVC backed textile and PVC resilient floor coverings.

**50mm x 25m / 5 Per Carton: 6495P**

STIKATAK® DOUBLE-SIDED TAPES



HEAVY DUTY CLOTH TAPE



A high quality cloth carrier with a heavy spread of white coloured hot melt adhesive. The release paper is an easy release silicone paper. Can be used on all types of floorcoverings excluding Vinyl Sheet and Tiles and any product that has plasticiser in its backing.

50mm x 50m / 20 Per Carton:  
B3-50/50

VINYL FLOOR TAPE



A quality double-sided tape produced specially for vinyls and floorcoverings with plasticisers in their backings. The adhesive used on this product is acrylic based to aid the prevention of plasticiser migration caused by an adverse reaction between the adhesive and the floorcovering backing.

50mm x 50m / 12 Per Carton:  
B4-50/50

GRIPPERRODS® DOUBLE-SIDED PMR CONTACT TAPES

CARPET TAPE



Stikatak double sided Vinyl Floor Tape is used for perimeter fixing of carpets.

48mm x 25m - 12 per pack:  
B8-48/25CB

PMR CONTACT TAPE



A construction grade impact adhesive coating giving a fast tack, high strength two way bond

- The PMR properties of our adhesive make this tape the only recommended application method for soft PVC covings and upstands
- A very fine web carrier that leaves no ridges or tramlines when applying thinner materials

25mm x 50m / 5Per Carton: 6470P  
50mm x 50m / 5Per Carton: 6471P

GRIPPERRODS® VAPOUR BARRIER TAPES

VAPOUR TAPE



A self-adhesive seaming tape for use with general products and also Timbermate Excel and Silentfloor Gold Underlays. The tape helps to create a moisture vapour barrier and strengthens underlay joints.

75mm x 25m / 24 Per Carton: 6450



STIKATAK® SINGLE-SIDED TAPES

WATER PROOF CLOTH TAPE



A good quality single sided tape for joining underlay in stretch installations.

50mm x 50m / 24 Per Carton:  
Black: C2-50/50-2

STIKATAK® FELT BACK CARPET FIXING TAPE

MUSHROOM TAPE



The professional way to fit felt back carpet.

- Specially designed to hook grip and secure your carpet.
- Solvent free adhesive
- Fast and easy to fit
- Easy to re-position and lift carpet after fitting
- No additional adhesive required
- Re-usable

50mm x 25m / 10 Per Carton: BF25

**SUPERSPRAY ADHESIVE**



General purpose aerosol adhesive for perimeter fixing of felt and foam backed carpets, underlays and tiles. Can also be used with foam, floor lining paper, textiles and fabrics to wood, stone, tiles and concrete (not to be used for expanded polystyrene and vinyls).

**S707**  
 500ml x 12 per pack  
 Coverage: Approx. 3 - 4m<sup>2</sup> per 500ml

**VINYL SPRAY ADHESIVE**



Vinyl Spray Adhesive for temporary or permanent bonding on most surfaces including vinyls (not to be used for expanded polystyrene).

**S735**  
 500ml x 12 per pack  
 Coverage: Approx. 2 - m<sup>2</sup> per 500ml

**SUPERSPRAY CONTACT ADHESIVE**



Spray Contact Adhesive with a high strength two-way bond and fast tack. Ideal for capping, coving, sit-on and set-in skirting. Variable nozzle can be adjusted to suit differing applications. Designed for fixing wood, carpet upstands, most metals, leather, cork, vinyl upstands, semi-flexible PVC nosings, rubber, textiles, PU foam, rigid 'unplasticised' PVC (not suitable for expanded polystyrene, linoleum and soft 'plasticised' PVC).

**S708**  
 750ml x 12 per pack  
 Coverage: 4.5 - 10.5m<sup>2</sup> per 750ml  
 single sided application

None of our spray adhesives contain Dichloromethane (DCM)

**GRIPPER ADHESIVE**



Gap filling synthetic rubber based mastic adhesive for fixing gripper and metal edgings to sub-floors and nosings to stair treads. Bonds most common building surfaces including wood, masonry, metal and some plastics. Can also be used for wall panels, skirtings, cladding and door frames (not suitable for expanded polystyrene).

**S7512**  
 310ml x 12 per pack  
 Coverage: Approx. 11 linear m per 310ml @ 6mm bead  
 Set time: 24 hours

**RAPIDBOND**



A high technology product formulated from a special adhesive system to withstand the rigours of plasticiser attack. Specified by many manufacturers of PVC backed textile and PVC resilient floor coverings.

**6616**  
 310ml x 12 per pack  
 Coverage: Approx. 44 linear m per 310ml @ 3mm bead  
 Set time: 1 hour

**CARPET STAIN REMOVER**



Proven instant results on carpets and upholstery in the home, car and workplace. With the instant foaming action stains are drawn out in seconds and wiped away. No water or rinsing required - just rub with a damp cloth. Pleasant smell, anti-static, easy, safe and effortless to use.

**S240**  
 400ml - 12 per pack

**GLUE WIPES**



Safe, heavy-duty double-sided cleaning wipes that combine a textured wipe with a hand cleaning solution. Specially formulated to remove glue, paint, grease, grout, oils and inks.

**S290**  
 4 x 100 wipes

Safety Information

Complete safety data sheets for our products can be found at: [interfloor.com/safety-data-sheets](http://interfloor.com/safety-data-sheets) ...or simply scan the QR code with your phone.





# HEAT SEAMING TAPES – HEATAC

Gripperrods® tapes are manufactured in our UK factory in a quality controlled environment, which ensures the very high standards that have made Gripperrods® the market leader in this product sector.

All tapes feature a woven scrim with a glass fibre weft and a polyester warp. The glass fibre gives maximum strength across the seam, the polyester allows some stretch along the length but none along the width as the glass fibre ensures stability.

We offer a range of different specification tapes to suit your various requirements. All are designed to give a strength of finished seam in excess of British Standards. The finished seam strength will also depend on selecting the right tape for the job and using the best tools.

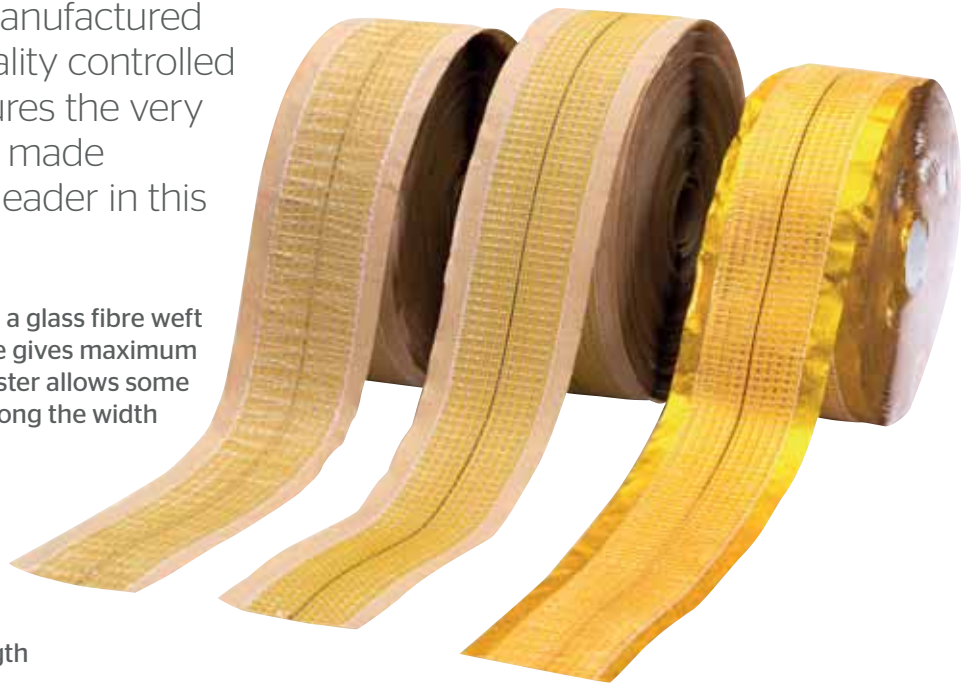

## HEAT SEAMING TOOLS

We provide a full range of heatseaming equipment in our Roberts tools section.



**Gripperrods®**

Product Code	Stitches Per Inch	Backing Type	Adhesive and Profile	Jute	Woven	Polypropylene	Felt Back
6736B	6-7	Foil	Supreme Ribbed	High Traffic	High Traffic	High Traffic	Not Recommended
6734/5B	6-7	Crepe Paper	Supreme Ribbed	High Traffic	High Traffic	High Traffic	Not Recommended
6727/8B	6-7	Crepe Paper	Supreme Flat	High Traffic	High Traffic	High Traffic	Not Recommended
6712/3B	5-6	Crepe Paper	Standard Ribbed	Moderate Traffic	Moderate Traffic	Not Recommended	Not Recommended
6730B	3-4	Foil	Standard Ribbed	Light Traffic	Light Traffic	Not Recommended	Not Recommended
6702B	3-4	Crepe Paper	Super LT and Special Ribbed	Light Traffic	Light Traffic	Not Recommended	Moderate Traffic

**Caution:** In some cases of secondary backings and heat set yarns, the heat transfer from seaming can cause delamination and/or pile reversal. If in doubt, a sample test should be carried out prior to installation.

**GOLD LINE****20m x 10 Per Carton : 6736B****Conventional woven or secondary jute backed carpets and Action-Bac**

Our top of the range tape is recommended for use in high traffic areas. Instead of the regular crepe paper backing it features a metallised gold foil that offers additional installation benefits:

- Reduces heat loss into the floor, giving a faster adhesive melt rate when the iron is applied and a faster seaming speed if required
- Slows down the adhesive cooling rate, allowing more working time for pattern matching
- Allows better control at lower temperatures for sensitive carpet piles and backings

**SEAMWELL****20m x 10 Per Carton: 6734B 100m x 2 Per Carton: 6735B****Conventional woven or secondary jute backed carpets and Action-Bac**

This tape offers an adhesive formulation and weight designed for high traffic installations and particularly for more difficult backings such as Action-Bac. The adhesive system is designed specifically to achieve good overall contact with these more rigid, uneven textured backings.

**STANDARD GOLD****20m x 10 Per Carton: 6730B****Conventional woven or secondary jute backed carpets**

A lower cost alternative to Gold Line tape. It offers the same installation benefits but is designed for light traffic areas only.

**SEAMWELL FLAT****20m x 10 Per Carton: 6727B 100m x 2 Per Carton: 6728B****Conventional woven or secondary jute backed carpets and Action-Bac**

This tape is designed for the same heavy wear areas and difficult backings as Seamwell but is for those installations where a flat adhesive profile is preferred.

**MULTILINE****20m x 10 Per Carton: 6712B 100m x 2 Per Carton: 6713B****Conventional woven or secondary jute backed carpets**

Designed for traditional backed carpets installed in moderate traffic areas.

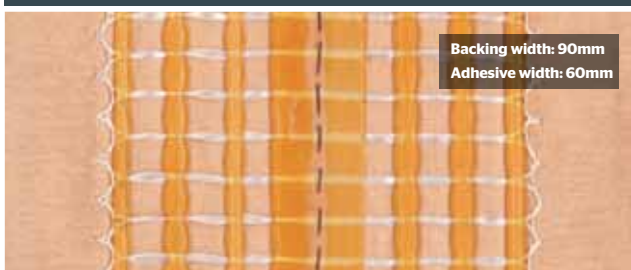
**STANDARD****20m x 10 Per Carton: 6702B****Felt backed carpet, conventional woven or secondary jute backed carpets**

This tape is designed for use in the fitting of felt backed carpets. The lower melt temperature of the adhesive prevents damage to the carpet backing.

The ribbed adhesive profile enables the tape to be centred automatically and ensures that the exact amount of adhesive is delivered for seam sealing.

This tape also provides a lower cost alternative to Multiline tape for seaming conventional woven or secondary jute backed carpets in light traffic areas.





## FITTING TOOLS

### The Brand Most Trusted By Pros

For decades, professional installers and DIYers alike have turned to ROBERTS® for dependable, high-performance flooring installation tools and accessories.

Working with industry experts, including certified trainers and top tradesman in their field, ROBERTS has elevated our offering to include the latest technologies, the most innovative design and craftsmanship, and the most installer-requested features.

It's no wonder why ROBERTS continues to be an industry leader and the brand most trusted by professional installers since 1938.

	Page
Preparation Tools	90
Hard Flooring Tools	100
Carpet Tools	106

FEATURING  
**FENTO**  
ERGONOMIC KNEE PROTECTORS™

# PREPARATION TOOLS



Whether the goal is to remove previous flooring or simply to prepare the space for brand new finishes, these tools will prove ideal for any task

R1056 (230V/1600W)  
R1056IND (110V/1400W)

## Long Neck Jamb Saw

**ROBERTS JAMB SAW is a fitters must have!**

Specifically for cutting door jambs, skirting boards and other hard to reach places using the swivel handle. The adjustable cutting depth guide prevents accidental cuts to ensure a professional and neat finish.



Item No.	Description	Interfloor Range
R1056	Long Neck Jamb Saw 230V/1600W	Core Range
R1056IND	Long Neck Jamb Saw 110V/1400W	Core Range
R1047	Carbide Tip Saw Blade	Core Range
R105524	Masonry Blade	Core Range

- Adjustable depth guide prevents cutting into plaster or wall board when trimming baseboards
- Extended rotating "tail" for maximum comfort and leverage against torque
- Cuts under toe kicks and full inside corners in moulding up to 12mm thick
- Extended blade guard lever for added safety
- Blade height adjusts from "flush" to 27mm
- 38mm vacuum port for optimal dust containment



230V

110V

**Custom moulded carry case** for protection and easy transportation between jobs.



# POWER TOOLS

## 1400W CONCRETE GRINDER

For the cutting and grinding of high spots on substrate substances such as screed, concrete and more.

- Supplied with 125mm grinding disc & grinding guard
- Includes 125mm dry cut diamond disc & cutting guard ideal for large format tiles
- Quick release lever on guards
- Spindle lock for easy disc change
- 3 position side handle
- Includes carry case for easy storage



Item No.	Description	Interfloor Range
R12550	1400W Concrete Grinder	Core Range
R12551	Grinder Cup	Core Range

## ELECTRIC MIXER

Roberts Electric Mixer is a powerful, variable speed mixer for efficient mixing.

- Powerful high torque motor for more efficient mixing
- Ergonomic handle to minimise fatigue
- Variable speed for greater control
- Safety on/off switch with lock-on function for continuous running
- Thermal overload protection for increased safety
- Robust carry case for ease of transportation
- Paddle - Ø140mm



Carry Case Included

Safety ON/OFF Switch

Replacement mixer paddles with an M14 thread connection.



Item No.	Description	Interfloor Range
R10120	Electric Mixer 230V/1600W	Core Range
R10120IND	Electric Mixer 110V/1400W	Core Range
MIXADH120	Mixer Paddle Ø120mm	Special Order
MIXADH140	Mixer Paddle Ø140mm	Special Order

# PREPARATION TOOLS

R10296

## Long Handled Floor Scraper

**LONG HANDLED FLOOR SCRAPER for removal whilst standing!**

Allows for the removal of flooring and adhesive without bending or kneeling.

- Stand-Up Scraper is perfect for removing old adhesive, vinyl, carpet, tile, and other floor covering materials.
- Steel shank with a cushioned grip handle.
- Adjustable from 900mm to 1800mm.



Item No.	Description	Interfloor Range
R10296	Extended Scraper	Core Range

## HEAVY DUTY SCRAPER

A lightweight, carbon steeled scraper ideal for removing tiles, adhesive, carpet and other flooring materials. Its long handle provides easy access to hard to reach areas, making it a great tool for wall and floor preparation.

- **10cm carbon steel blade**
- **Ideal for removing tiles, adhesive, carpet and other flooring materials**
- **Cushioned grip handle**



Item No.	Description	Interfloor Range
R10196	Heavy Duty Scraper	Core Range
R10455	10cm Spare Blades	Special Order

R1010

# Carpet Remover

**THE IDEAL TOOL FOR TEAR-OUT AND REMOVAL FOR LARGE PIECES OF FLOORING!**

Perfect for removing large areas carpets, vinyl and plywood.

- Large comfortable handle with a unique hinge mechanism to maximise pulling power
- Serrated clamps provide an extremely firm grip

Item No.	Description	Interfloor Range
R1010	Carpet Remover	Core Range



## 7.5M HEAVY DUTY TAPE MEASURE

A 7.5m heavy duty tape measure with rubber outer case and plastic inner case.

- **Imperial and Metric measurements**
- **Locking Device**

Item No.	Description	Pack Size
NJ23A	7.5m Heavy Duty Tape Measure	Box of 24



## PRO MINI PRY BAR

Engineered from high carbon forged steel. Curved design with notched ends for easy nail removal.

- **32° angle provides ideal leverage**
- **Deep bevel nail slot for easy nail removal**
- **Small enough to fit in your toolbox**

Item No.	Description	Interfloor Range
R510	Pro Mini Pry Bar	Core Range



## GRINDING STONE

Roberts Grinding Stone is a stone with a handle for sanding any seams in wooden/MDF subfloors.

- **Grit 24 Grinding Stone**
- **Removes imperfections on subfloor prior to installation**

Item No.	Description	Interfloor Range
R10615	Grinding Stone	Core Range



# PREPARATION TOOLS

## STRIP CUTTER

This rugged cutter provides a strong cutting force, with a comfortable handle for ease of use.

- **Powerful 8 to 1 cutting force**
- **Ideal for cutting carpet grippers and architectural strip**

Item No.	Description	Interfloor Range
R10108	Strip Cutter	Core Range
R10439	Strip Blades (6 pack)	Special Order



## SMOOTHEDGE SHEARS

Ideal for cutting carpet gripper with a high quality steel cutting blade

- **Safety anvil holds shears closed while not in use**

Item No.	Description	Interfloor Range
R570	Smoothedge Shears	Core Range



## NAIL DRIVING BAR

The Nail Driving Bar is the perfect solution for hammering nails in hard-to-reach places including under radiators, toe kicks, overhangs and next to glass doors.

- **For use when positioning and hammering nails in hard-to-reach places**
- **Designed with an ergonomic non-slip grip to easily position and hold nails in tight places**
- **19mm magnetic head**

Item No.	Description	Interfloor Range
R10151	Nail Driving Bar	Special Order



## STAPLE HAMMER

Staples down a variety of flooring types. The perfect fitter's friend!

- **Durable stamped steel**
- **Comfortable vinyl grip**
- **Easy back-end loading**

Item No.	Description	Interfloor Range
R10109	Staple Hammer	Core Range
NJ54	8mm Staples (5000 pack)	Core Range
NJ55	10mm Staples (5000 pack)	Core Range



# TROWELS & ADHESIVE SPREADERS

## 3mm SQUARE NOTCH TROWEL

Ideal for mosaic and parquet flooring. Designed for professional installers.

- High-quality tempered steel blade for durability
- Large wood handle for firm, comfortable grip

Item No.	Description	Interfloor Range
R49766	3mm Square Notch Trowel	Special Order



## 1.5mm SQUARE NOTCH TROWEL

Best for carpet tiles and underlay. Designed for professional installers.

- High-quality tempered steel blade for durability
- Large wood handle for firm, comfortable grip

Item No.	Description	Interfloor Range
R49768	1.5mm Square Notch Trowel	Special Order



## 1.5mm U-NOTCH TROWEL

Optimised for vinyl and LVT. Designed for professional installers.

- High-quality tempered steel blade for durability
- Large wood handle for firm, comfortable grip

Item No.	Description	Interfloor Range
R49771	1.5mm U-Notch Trowel	Core Range



## 6mm FLAT TOP V NOTCH TROWEL

Excellent for solid and engineered wood. Designed for professional installers.

- High-quality tempered steel blade for durability
- Large wood handle for firm, comfortable grip

Item No.	Description	Interfloor Range
R49769	6mm Flat Top V Notch Trowel	Core Range



## ECONOMY 2-SIDED NOTCHED TROWEL

Suitable for a range of flooring including carpet and vinyl. 1.5mm square and U shaped notches.

- Engineered for extended wear and tear
- Designed for pressure sensitive, resilient adhesives

Item No.	Description	Interfloor Range
R10181	Economy 2-Sided Notched Trowel	Special Order



## ADHESIVE SPREADERS

Ergonomic handles ensure maximum comfort.

- A2 for LVT, vinyl sheet & commercial vinyl
- B1 for LVT, carpet and vinyl
- B2 for needle punch carpet

Item No.	Description	Interfloor Range
RASA2	18cm A2 Adhesive Spreader	Core Range
RASB1	18cm B1 Adhesive Spreader	Core Range
RASB2	25cm B2 Adhesive Spreader	Core Range



# TOOL STORAGE & PROTECTION

## FITTERS TOOLBOX

Built to last, with heavy-duty steel construction and a premium finish. Features an innovative, built in seaming plate (on the bottom of the storage tray).

- Spacious: L 610mm x W 248mm x D 222mm
- Integrated locking loops
- Heavy duty locking latches
- Tough inset side handles
- Soft grip handle



Item No.	Description	Interfloor Range
R10163	Fitters Toolbox with Seaming Plate	Special Order

## TOOL BAG

This Tool Bag has a range of pockets to help organise and separate consumables whilst allowing quick 'on the job' access to smaller tools like tapes and nails.

- 8 external pockets
- 4 internal pockets
- Flexible carrying handles for easy transportation
- Shoulder strap
- Holds up to 20kg



Item No.	Description	Interfloor Range
RTOOLBAG	Tool Bag	Core Range

## DELUXE GRIP LEATHER POUCH

This pouch is 190 x 114 x 19mm with one large pocket that provides ample space to fit a variety of tools as needed.

- 100% leather with double stitching for extended wear and longer product life
- Holds tools firmly in place with special leather inserts grips
- Easily attaches to belt and stays in place without shifting
- Ample space to fit a variety of tools as needed



Item No.	Description	Interfloor Range
R10260	Deluxe Grip Leather Pouch	Core Range

## PRO KNEE PADS

Premium knee pads for increased protection whilst installing flooring including carpets, engineered wood, LVT, linoleum and vinyl. Also useful for protecting knees during removals.

- Perfect knee protection against all flooring types
- Soft, non-pinching straps
- Wide straps that hold knee pads in place
- Padded upper strap specifically designed to be used during knee kicking



Item No.	Description	Interfloor Range
R79034	Pro Knee Pads	Core Range

## FENTO ORIGINAL

The all-round model.

- **Hardwearing and waterproof outer layer**
- **Wide support area for maximum stability**
- **The whole product is easy to clean**
- **Breathable inlay distributes pressure over knee and lower leg to prevent back and knee complaints**
- **Replaceable inlay**
- **Elastic straps do not constrict behind the knee**



Item No.	Description	Interfloor Range
F280220	FENTO Original	Core Range

## FENTO MAX

Specially made for extra intensive usage.

- **Hardwearing and waterproof outer layer**
- **Wide support area for maximum stability**
- **The whole product is easy to clean**
- **Breathable inlay distributes pressure over knee and lower leg to prevent back and knee complaints**
- **Replaceable inlay**
- **Elastic straps do not constrict behind the knee**



Item No.	Description	Interfloor Range
F280440	FENTO Max	Core Range

## FENTO BOARD

Specially made to create extra mobility.

- **The handle on top of the knee protector makes it possible to carry it around, which enables great mobility**
- **Wide support area for maximum stability**
- **The knee protector distributes pressure over the knee and lower leg to prevent knee and back complaints**
- **The knee protector is easy to clean, has a hard wearing outer layer and has just enough weight to not be taken away by the wind**



Item No.	Description	Interfloor Range
F280500	FENTO Board	Core Range

## FENTO POCKET

Specially made to fit in your work trousers.

- **3D moisture management fabric**
- **Ergonomic wedge for unique pressure distribution**
- **Breathable**
- **Waterproof and strong**
- **Comfortable and durable**
- **Fits practically every type of work trousers**



Item No.	Description	Interfloor Range
F280100	FENTO Pocket	Core Range

## PROTECTION CAPS

Fits Original and Max.

- 100% comfort

Item No.	Description	Interfloor Range
P280002	Protection Caps	Core Range



## INLAYS

Fits Original.

- 100% comfort

Item No.	Description	Interfloor Range
P280003	Inlays	Core Range



## INLAYS

Fits Max.

- 100% comfort

Item No.	Description	Interfloor Range
P280004	Inlays	Core Range



## ELASTICS WITH VELCRO

Fits Original.

- Quantity 2

Item No.	Description	Interfloor Range
E280201	2 Elastics with Velcro	Core Range



## ELASTICS WITH VELCRO

Fits Max.

- Quantity 4

Item No.	Description	Interfloor Range
E280401	4 Elastics with Velcro	Core Range



## ELASTICS WITH CLIP

Fits Original.

- Quantity 2

Item No.	Description	Interfloor Range
E280202	2 Elastics with Clip	Core Range



## ELASTICS WITH CLIP

Fits Max.

- Quantity 4

Item No.	Description	Interfloor Range
E280402	4 Elastics with Clip	Core Range



A person wearing blue jeans and black knee pads is using a red-handled multi-floor cutter tool. The tool has a long red handle and a red frame that supports three large, cylindrical metal rollers. The person is standing on a wood-grain floor, and the background is a plain grey wall.

# HARD FLOORING TOOLS

Specifically engineered for the installation of wood and laminate floors, our multi-floor cutters and individual flooring tools are precision crafted and thoughtfully designed.

# FLOORING CUTTERS

## 630mm/25" PROFESSIONAL FLOORING CUTTER

The Professional Flooring Cutter is a guillotine-style cutter manufactured to cut precise, clean edges on all types of flooring materials up to 16mm/5/8" thick and 630mm/25" wide.

The Extendable handle provides extra power which is great not only for cutting laminate and engineered wood, but also for cutting a variety of other flooring materials such as carpet tile, vinyl flooring, LVT, VCT tiles, rubber, foam and more.

- Cuts flooring materials up to 16mm thick and 630mm wide
- Large cutting table for longer planks
- Extendable handle for maximum cutting power



Item No.	Description	Interfloor Range
R10-95	Professional Flooring Cutter	Core Range
R10-95SET	630mm Blade, 2 Nylon Bars & Screws	Special Order

## 330mm MULTI-FLOOR CUTTER

The Roberts 330mm Multi Floor Cutter is designed to easily cut several materials up to 33cm wide, making flooring installations faster.

The Multi Floor cuts laminate and engineered wood flooring, LVP, LVT, SPC, WPC flooring, VCT, MDF, soft plastic, vinyl siding and fibre cement siding.

- Cuts material up to 330mm wide and 12mm thick
- Long handle provides extra leverage for more cutting power with less effort
- Elliptical rotating motion grants smooth, constant cutting pressure for clean cuts
- Sturdy aluminium support base with a solid plastic surface for a comfortable working area
- Table mitre guide for 0 to 45° angle cuts
- Long lasting, HSS blade provides a sharp cutting edge (replacement blades sold separately)
- Easy locking system

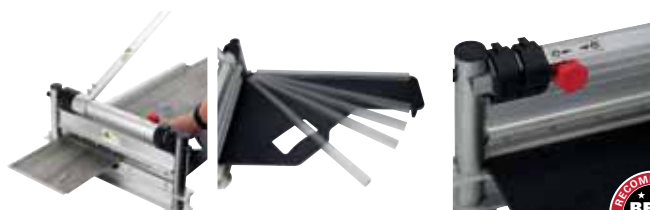

Item No.	Description	Interfloor Range
R1061A	330mm Multi-Floor Cutter	Core Range
R1061RB	Replacement Blade for R1061A	Special Order

# CUTTERS / INSTALLATION TOOLS

## 450mm/18" VINYL TILE CUTTERS

This lightweight cutter delivers precise rip cuts on flooring up to 450mm/18" and 300mm/12" diagonally.

- Industrial grade carbon steel blade
- Cutting guides for perfect cuts
- Cuts LVT, rubber, cork and VCT up to 3mm thick

Item No.	Description	Interfloor Range
R10918	450mm/18" Vinyl Tile Cutter	Special Order
R1091805	450mm/18" Top Blade	Special Order
R1091806	450mm/18" Lower Blade	Special Order



## 300mm/12" VINYL TILE CUTTERS

This lightweight cutter delivers precise rip cuts on flooring up to 300mm/12" and 229mm/9" diagonally.

- Industrial grade carbon steel blade
- Cutting guides for perfect cuts
- Cuts LVT, rubber, cork and VCT up to 3mm thick

Item No.	Description	Interfloor Range
R10900	300mm/12" Vinyl Tile Cutter	Core Range
R1090005	300mm/12" Top Blade	Special Order
R1090006	300mm/12" Lower Blade	Special Order

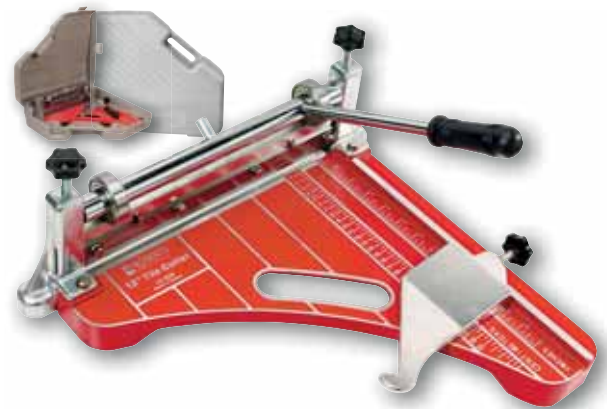

## PRO VINYL FLOORING KNIFE

High-quality, versatile knife cuts and tucks with ease and precision.

- Curved blade slices linoleum, vinyl sheet goods and carpet
- Tapered, flat-top surface for use as a carpet tucker
- Blade made from hardened stainless steel for extra durability
- Ergonomic grip for enhanced performance and comfort

Item No.	Description	Interfloor Range
R10925	Pro Vinyl Flooring Knife	Core Range



## GROOVER

The Roberts Groover for putting steady grooves into tough flooring. Ideal for PVC, Linoleum and Vinyl floors.

Item No.	Description	Interfloor Range
R50001	Groover	Special Order
R50002	Spare Front Blade for R50001 Groover	Special Order
R50003	Spare Rear Blade for R50001 Groover	Special Order
R50004	Spare Front Plate for R50001 Groover	Special Order
R50005	Spare Rear Plate for R50001 Groover	Special Order
R50006	Spare Guide Roller for R50001 Groover	Special Order



# INSTALLATION TOOLS

R1049

## DOUBLE TAP™ Tapping Block

Designed to push flooring planks together without damaging the joining grooves!

- Double-sided with notches designed for tongue and groove, click-lock laminate, engineered wood, or vinyl tile planks
- D-handle can be removed and reattached to either side of the block
- Offset handle keeps hands away from strike zone

Item No.	Description	Interfloor Range
R1049	Double Tap™ Reversible Tapping Block	Core Range



## THE MAVERICK™ WIDE ANGLE PULL BAR

Roberts THE MAVERICK™ Wide Angle Pull Bar is a heavy-duty tool that does not bend against mallet hits. It is ideal to close gaps and tighten seams in small spaces during laminate and wood flooring installation.

- This pull bar features a triangle head that absorbs 10 times the strike force of a standard pull bar.
- Reaches against a wall or other hard to reach spaces
- Extra long 41cm length

Item No.	Description	Interfloor Range
R10018	Maverick Wide Angle Pull Bar	Core Range



## DOUBLE HEADED HAMMER

Non-marring and double faced mallet for use with tapping block and pull bar. Co-moulded plastic handle with rubber grip handle for comfortable repeat use.

- Chamfered edges maximise contact with subfloors when positioning flooring.
- Ideal for use with the Maverick Pull Bar and Double Tap Reversible Tapping Block

Item No.	Description	Interfloor Range
R10431	Double Headed Hammer	Core Range



# INSTALLATION TOOLS

## FLOORING INSTALLATION KIT

The Flooring Installation Kit is used to install tongue and groove flooring as well as glue-down and floating floor applications.

Kit includes:

- Tapping Block,
- Pull Bar,
- 30 Wedge Spacers



Item No.	Description	Interfloor Range
R1028	Flooring Installation Kit	Core Range

## LAMINATE FLOORING EXPANSION SPACERS

For glued and floating laminate. Maintains an even expansion gap when installing flooring

- Pack of 30 Spacers
- Wedge shaped for easy placement and removal while maintaining small gap
- Ridged surface to prevent slippage in use
- 3mm to 7mm thickness range
- Reuseable plastic design
- Max weight for spacers is 12kg

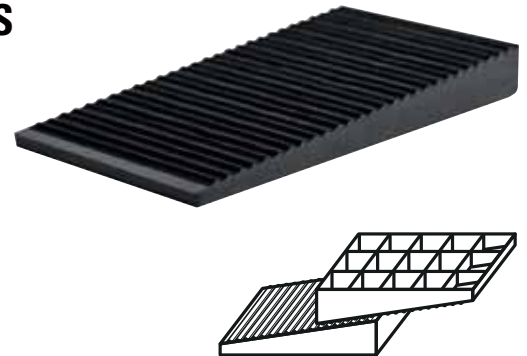

Item No.	Description	Interfloor Range
R1027	Laminate Flooring Expansion Spacers	Core Range

## GLIDER

Heavy metal glider ensuring perfect adhesion of underlay to sub-floor and floor coverings to underlay backing in stickdown installations.

- Working width 38 cm (1'3") - for dual purpose
- Weight approx. 10 kg (22 lbs)
- Handle length 120 cm (3'11¼")



Item No.	Description	Interfloor Range
TAS013	Glider	Core Range



## TEC 3400 HOT MELT GLUE GUN

A heavy duty Hot Melt Glue Gun, TEC 3400. This gun is used by professional floorcovering contractors where extensive gluing is required on site.

- Suitable for materials such as gripper, metal edgings and nosings.
- Uses 43mm x 50mm Glue Cartridges



Item No.	Description	Pack Size
NJ34	Hot Melt Glue Gun	1

Item No.	Description	Pack Size
NJ25	43mm x 50mm Glue Cartridge	5kg

# ROLLERS

## SPIKED ROLLER 250mm

This is perfect for subfloor preparation, effectively removing bubbles in floor levelling compounds. With a 250mm width and 21mm tooth height, it's designed to fit seamlessly into smaller areas.

- Heavy-duty steel frame accepts standard push fit extension rollers and broom handles
- Best for smaller spaces and corners
- Tooth height 21mm



Item No.	Description	Interfloor Range
R2003	250mm Spiked Roller	Special Order

## SPIKED ROLLER 500mm

Ideal for subfloor preparation by helping to remove bubbles in floor levelling compounds. Fitted with a heavy duty steel frame which accepts standard push fit extension rollers and standard size broom handles.

- Heavy-duty steel frame accepts standard push fit extension rollers and broom handles
- Ideal for larger spaces
- Tooth height 21mm



Item No.	Description	Interfloor Range
R2001	500mm Spiked Roller	Core Range

## EXTENDABLE FLOOR ROLLER

The roller is a non-marking roller to help smooth out uneven vinyl floor covering, carpet or wall covering. Non marking 180mm wide segmented rollers aid pressure on uneven surfaces. Extending handle from 430mm to 680mm.

- Second handle for additional leverage
- Suitable for rolling vinyl floor covering, carpet and cove bases
- Can also be used for wall covering



Item No.	Description	Interfloor Range
R10975	Extendable Floor Roller	Core Range

## HEAVY DUTY LINOLEUM ROLLERS

This roller is perfect for rolling vinyl floor covering and carpets. The wide segmented roller head exerts constant pressure, ideal for levelling and removing trapped air between the substrate and flooring.

- 39cm wide segmented roller head exerts constant pressure
- Flattens adhesive build-ups, ensuring level installation



Item No.	Description	Interfloor Range
R10945	30kg Heavy Duty Linoleum Rollers	Core Range
R10952	45kg Heavy Duty Linoleum Rollers	Special Order

# CARPET TOOLS

A close-up photograph of a person's hand holding a silver metal carpet tool handle. The hand is positioned over a light-colored, textured carpet. In the background, a black tool bag with the 'ROBERTS' logo is visible. The logo consists of a globe icon followed by the word 'ROBERTS' in white capital letters. The overall scene is set against a dark background, likely the interior of the tool bag or a similar setting.

**ROBERTS**

Designed with professional installers in mind. From Knee Kickers to Seaming Irons you can expect quality and satisfaction from all of our carpet tools.

R102100

# The GENERAL™ KNEE KICKER

THE GENERAL features an extra-wide 5"/127mm head, four nap grip strips and five rows of steel pins to manoeuvre carpet with ease and precision

- Engineered gel pad
- 28% wider head
- Innovative professional Knee Kicker
- Gel Core bumper that absorbs kinetic energy from a knee strike, lessening the impact to the knee while providing optimum driving impact.
- Contoured, heavy duty "bullneck" body design
- Quick release for adjusting the extension arm.



5 ROWS OF STEEL PINS & 4 NAP GRIPS  
**ENSURE  
MAXIMUM  
GRIP**

Item No.	Description	Interfloor Range
R102100	The General Extra Wide Knee Kicker	Core Range
R10200003	Kicker Nap Insert (with Screws x4)	Special Order
R10200004	Pin Plate Assembly	Special Order



# KNEE KICKERS

## GT2000 KNEE KICKER

28% wider head than other models giving more gripping power. Aluminium die-cast body for maximum strength whilst being lightweight and easy to handle.

- High contour neck fits over stretch poles and heads
- Aluminium die-cast body for strength whilst remaining lightweight
- 5 extendable positions range from 470-570mm



Item No.	Description	Interfloor Range
R102000GT	GT 2000 Knee Kicker	Core Range
R10200003	Kicker Nap Insert (with Screws x4)	Special Order
R10200004	Pin Plate Assembly	Special Order
R10200009	Kicker Bumper with Screws	Special Order

## DELUXE KNEE KICKER

The Deluxe Knee Kicker is Extendable in 5 positions, ranging from 430-530mm. It has a heavy duty die-cast aluminium body.

- High contour neck fits over stretch poles and heads
- Available in silver or black



Item No.	Description	Interfloor Range
R10412	Deluxe Knee Kicker Silver	Core Range
R10412BK	Deluxe Knee Kicker Black	Core Range
R41203	Kicker Nap Insert	Special Order
R41204	Pin Plate Assembly	Special Order
R41209	Kicker Bumper with Screws	Special Order
R42209	Kicker Bumper with Extra Thick Screws	Special Order

## GT EXTENDABLE KNEE KICKER

The GT Extendable Knee Kicker has a wider head for improved load distribution and an easy to use trigger release which adjusts the length from 445mm - 545mm.

- High contour neck fits over stretch poles and heads
- Centrally grooved for adjusting a power stretched head



Item No.	Description	Interfloor Range
R10422	GT Extendable Knee Kicker	Core Range
R41203	Kicker Nap Insert	Special Order
R5017A	Pin Plate Assembly	Special Order
R41209	Kicker Bumper with Screws	Special Order
R42209	Kicker Bumper with Extra Thick Screws	Special Order

# CARPET KNIVES

## 3-IN 1 CARPET, VINYL & UTILITY KNIFE

For use with carpet and LVT/LVP or as a utility knife to cut twine and cardboard. NEW SWIVEL GRIP™ blade storage accommodates 20 individual blades or most 10-pack cartridges

- Can be used with carpet, utility, trimmer, hook or concave blades according to need
- Features patented insert with 3 positions according to blade type and cutting use

Item No.	Description	Interfloor Range
R10216	3-in-1 Carpet, Vinyl & Utility Knife	Core Range
R10260	Deluxe Grip Leather Pouch	Core Range



• See replacement blades below

• Available Separately

## PRO DUAL-DEPTH CARPET KNIFE

Features a patented insert with two depth positions for use according to the carpet-back thickness.

- Patent-pending blade spindle has extended tangs to prevent blades from slipping through gaps
- Top of knife is curved for improved comfort and control
- Recessed nose bottom offers more exposure of blade for slicing

Item No.	Description	Interfloor Range
R10259	Pro Dual-Depth Carpet Knife	Core Range
R10260	Deluxe Grip Leather Pouch	Core Range



• Available Separately

## CUT & JAM CARPET KNIFE

Unique dual function design for cutting carpet and tucking carpet into gullies. The rugged yet lightweight, precision die cast aluminium design.

- Easy-to open design allows for fast blade change
- Safety thumb and blade guard for additional safety
- Slip-resistant handle provides firm grip for precise, clean cuts
- Includes 3 blades

Item No.	Description	Interfloor Range
R10220	Cut & Jam Carpet Knife	Special Order
R10260	Deluxe Grip Leather Pouch	Core Range



• Available Separately

## UTILITY KNIFE

The Roberts Utility Knife is a high quality steel knife ideal for the installation of multiple floor covering types.

- High quality steel blade
- Lightweight for easy carrying

Item No.	Description	Interfloor Range
R10221	Utility Knife	Core Range
R10226	Utility Knife Sheath	Special Order



• See replacement blades below

• Available Separately

## REPLACEMENT BLADES



Item No.	Description
N21	Replacement Blades 2000* pack
N22	Replacement Blades 500† pack

\* 2000 (4 x 5 boxes of 100) | † 500 (5 boxes of 100)

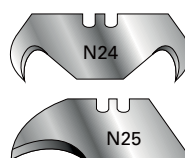

Item No.	Description
N24	Replacement Blades 500* pack
N25	Replacement Blades 500* pack

\* 500 (5 boxes of 100)

# TRIMMERS

## DELUXE CARPET TRIMMER

Trims carpet neatly at the wall and under toe kicks. Five position folding handle moves easily for hard to reach areas.

- Efficiently cuts loop pile carpet of any thickness
- Accommodates both left and right positions
- Cuts closer to the yarn edge



Item No.	Description	Interfloor Range
R10616	Deluxe Carpet Trimmer	Core Range



## UNIVERSAL SEAM CUTTER

A dual function tool which has a top blade for top cutting and a trimmer blade for bottom cutting.

- Ergonomic grip for comfort and efficiency

Item No.	Description	Interfloor Range
R101543	Universal Seam Cutter	Special Order



## LOOP PILE CARPET CUTTER

Efficiently cuts most loop pile carpet regardless of thickness. A unique two-blade design accommodates both left and right positions for cutting closer to the yarn edge.

- Efficiently cuts loop pile carpet of any thickness
- Accommodates both left and right positions
- Cuts closer to the yarn edge

Item No.	Description	Interfloor Range
R10152	Loop Pile Carpet Cutter	Core Range



## GRIPPERRODS® INVISISEAMER®

The definitive tool for cutting carpets prior to seaming. Invaluable for border work.

- Supplied with a 73cm (2'5") base



Item No.	Description	Pack Size
TMM013	Gripperrods® Invisiseamer®	1
TMM015	1.83m (6') Base Only	1
TMM016	3.66m (12') Base Only	1



## TRIM MASTER

Ensures a precise cut together with a professional finish when trimming carpet or vinyl.

- Extremely light in weight and comfortable to hold
- Adjustment to both the angle and the depth of the blade is extremely easy
- Allows long lengths of the floor covering to be trimmed accurately
- Standard hooked or straight blades can be used see page 25 for replacement blades



Item No.	Description	Interfloor Range
N2100S	Trim Master	Core Range



• See replacement blades on page 25

# SHEARS

## 25cm CARPET SHEARS

High quality carbon steel with large handles and extra wide, cushioned openings for superior quality and durability.

- **Blade length (25cm)**
- **Large handles and extra wide, cushioned openings**

Item No.	Description	Interfloor Range
R10123	25cm Carpet Shears	Core Range



## 30cm CARPET SHEARS

High quality carbon steel with large handles and extra wide, cushioned openings for superior quality and durability.

- **Blade length (30cm)**
- **Large handles and extra wide, cushioned openings**

Item No.	Description	Interfloor Range
R10125	30cm Carpet Shears	Core Range



## LEFT HANDED CARPET SHEARS

Premium quality, large stainless steel shears. Superior cutting quality and durability.

- **Blade length (25cm)**
- **Large handles and extra wide, cushioned openings**

Item No.	Description	Interfloor Range
R10124	Left Handed Carpet Shears	Special Order



## DELUXE NAPPING SHEARS

The Roberts Deluxe Napping Shears are a large pair of premium quality shears with superior cutting .

- **Blade length (20cm)**
- **Superior cutting quality and durability**

Item No.	Description	Interfloor Range
R10121	Deluxe Napping Shears	Core Range



## DUCKBILL SHEARS

Premium quality high carbon steel, offset handle and special blade prevent gouging.

- **High carbon steel**
- **Superior cutting quality and durability**

Item No.	Description	Interfloor Range
R586	Duckbill Shears	Core Range



# POWER STRETCHERS

R10254A

## Power Stretcher

**POWER STRETCHERS are the perfect tools for installing wall to wall carpets!**

Additional extensions are available to ensure you can carpet in even the largest areas

- Low profile swivel head
- Locking device in the handle to avoid needing to adjust the tubes
- Available in a custom moulded carry case complete with wheels to ensure easy transportation and protection between jobs
- Includes four aluminium extension tubes

### Includes Carry Case



Item No.	Description	Interfloor Range
R10254A	Powerlok Stretcher GT	Core Range
R1023510	Extension Tube	Special Order
R10-250	Locking Tube	Special Order

## SEAM/RE-STRETCHER

The Seam Stretcher has been designed for use in tight areas and where the tail block of the Powerlok Stretcher can't be braced against the opposite wall. It is extremely versatile and compact - the perfect 'go to' tool.

- Suitable for use in tight areas
- Versatile and compact
- Unique shovel design for seam repairs and directional stretching

Item No.	Description	Interfloor Range
R10128	Seam/Re-Stretcher	Special Order



# CARPET INSTALLATION TOOLS

Used to set the carpet into the tack strip, drive the carpet into gullies and crease the carpet along the wall line for a professional flooring finish.

- 10cm stair tool for faster carpet tucking

Item No.	Description	Interfloor Range
R521	Stair Tool	Core Range



## CARPET TUCKER

This lightweight nylon Carpet Tucker is ideal for use on delicate flooring areas and will not mark or damage walls.

- Lightweight nylon base material

Item No.	Description	Interfloor Range
R10522	Carpet Tucker	Core Range



## ROLLING CARPET TUCKER

The Rolling Carpet Tucker allows the professional installer to tuck 5 times faster than conventional methods.

- Non-slip handle providing better grip and control

Item No.	Description	Interfloor Range
R10523	Rolling Carpet Tucker	Core Range



## SPEEDCAT CARPET TUCKER

Wheels to revolutionise the carpet fitting trade by speeding up the process of creasing and tucking carpets into place saving time and money.

- An ideal product for the flooring professional

Item No.	Description	Interfloor Range
N2300S	Speedcat Carpet Tucker	Core Range



## CARPET CARRIER

Sturdy, tubular steel frame, large pneumatic tyres and smooth roller bearings absorb heavy loads in the warehouse or showroom.

- Maximum safe working load 400 kilos.

Item No.	Description	Pack Size
THP001	Carpet Carrier	1



# INSTALLATION TOOLS & ADHESIVES

## CARPET SEAM ROLLER

Has a 100mm wide head, which is ideal for seaming carpets. Designed to maximise the transfer of hot-melt tapes into the carpet and produce a stronger seam.

- Increased hotmelt transfer for stronger seams



Item No.	Description	Interfloor Range
R10169	Carpet Seam Roller	Core Range

## CARPET AWL

Awl is ideal for tucking carpet at baseboards as well as use for upholstery work. Cushion grip adds comfort to utility.



Item No.	Description	Interfloor Range
R530	Carpet Awl	Core Range

## ROW FINDER

Separate carpet rows to minimise damage to nap and loops. Featuring a tapered round end for cut pile and flattened end loop for pile carpets.

- Tapered round end for cut pile
- Flattened end for loop pile carpets



Item No.	Description	Interfloor Range
R10517	Row Finder	Core Range

## ANTI FRAY SPRAY

Prevents carpets from fraying while cutting. Can be used with woven carpets, sisal, coco, carpet-tiles, underpadding, clothing, felt and carton.

- Dries clear for a neat finish without leaving a sticky residue
- 1 year shelf life
- Boxed in 12 x 500ml cans



12 per Box



Item No.	Description	Interfloor Range
R532	Anti Fray Spray	Core Range

## CARPET SEAM SEALER

A zero VOC sealer that dries clear and cleans up with soap and water (235ml). For seaming all carpet edges, to prevent unravelling and de-laminating.

- Fast drying, synthetic polymer formula
- Solvent-free
- Microban mould protection
- Boxed in 12 x 235ml bottles



12 per Box

Item No.	Description	Interfloor Range
R8015A	Carpet Seam Sealer 235ml	Core Range

# HEAT BOND IRONS

## COOL SHIELD® SEAMING IRON

Seaming iron melts heat bond tape, quickly and easily while maintaining a cooler top shield temperature. Patented double heat shield minimises deforming of carpet backing and face yarn.

- Even heat distribution for thorough melting whilst maintaining a cooler top shield temperature
- S' shaped heating element for even heating and heat retention
- Grooved non-stick plate for fast easy clean up



Item No.	Description	Interfloor Range
R10483EG	Cool Shield Seaming Iron	Core Range

## DELUXE CARPET SEAMING IRON

This Deluxe Carpet Seaming Iron allows for easy carpet seaming thanks to the even heat distribution for thorough melting.

- Even heat distribution for thorough melting
- Grooved non-stick plate for fast easy clean up
- Low profile design



Item No.	Description	Interfloor Range
R10282EG	Deluxe Carpet Seaming Iron	Core Range



## WIDE HEAT SEAMING IRON

Heat-Bond Carpet Seaming Iron gives double the seaming capacity. Designed to distribute heat evenly, its 152mm wide soleplate provides wider, better coverage for use with seam tape.

- Even heat distribution for thorough melting
- Convenient 3-way cord adjustment keeps the cord out of the way while installing
- Convenient iron storage tray safely holds seaming iron when not in use
- Use with Wide Heat Seaming Tape

Item No.	Description	Interfloor Range
R10286EG	Wide Heat Seaming Iron	Special Order



## Gripperrods® HEAT SEAMING TAPE

Gripperrods® tapes are manufactured in the UK in a quality controlled environment. We offer a range of different specification tapes to suit your various requirements. All are designed to give a strength of finished seam in excess of British Standards. The finished seam strength will also depend on selecting the right tape for the job and using the best tools.

For details our full range of flooring and heat seaming tapes contact Sales on 01706 238810 or view online [www.interfloor.com/accessories/tapes/](http://www.interfloor.com/accessories/tapes/)

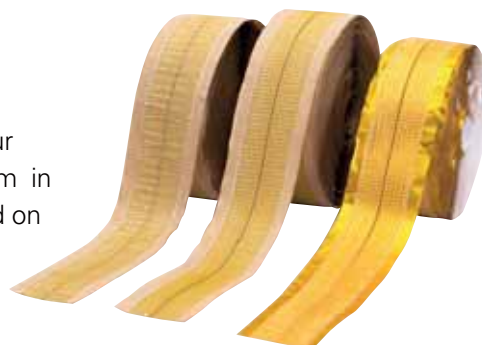

## RETAIL PACKAGED PRODUCTS

# HELPING CUSTOMERS CREATE THE PERFECT INSTALLATION

A range of retail packaged flooring accessories including:

- Carpet Gripper
- Metal Edgings
- Carpet & Rug Protection
- Wrapping & Packing
- Merchandising Stands

### METAL EDGINGS - VINYL & CARPET

#### CARPET

The angled ribs extruded on the underside lock into the carpet pile and draw the two edges together when the strip is screwed to the floor. Suitable for use with all types of carpet. High lustre polished aluminium. Includes Screws and fixings.

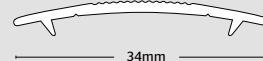

0.90m x 10 Per Carton

ALUMINIUM:

**M19P3A**

### WOOD & LAMINATE EDGINGS

#### ANGLE EDGE - 8MM SELF-ADHESIVE

Gives a smooth transition down to resilient floorings.



STICK  
DOWN



0.90m x 10 Per Carton

MATT ALUMINIUM:

**M04P3AMA**

MATT GOLD:

**M04P3GMA**

#### EURO COVERSTRIP - 38.5MM SELF-ADHESIVE

High quality self-adhesive coverstrip for use with most flooring types of equal levels.



STICK  
DOWN

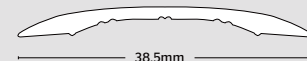

0.90m x 10 Per Carton

MATT ALUMINIUM:

**M13P3AMA**

MATT GOLD:

**M13P3GMA**

#### NOSINGS - 9MM SELF-ADHESIVE

Designed to give a neat join across the doorway in stretch carpet to carpet installations.

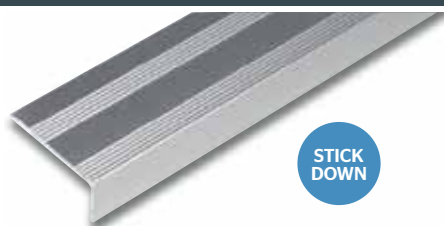

STICK  
DOWN

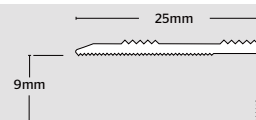

0.90m x 10 Per Carton

MATT SILVER:

**M74P3AMA**

## TAPES

### STIKATAK® VINYL FLOOR TAPE

A quality double-sided tape produced specially for vinyls and floorcoverings with plasticisers in their backings. The adhesive used on this product is acrylic based to aid the prevention of plasticiser migration caused by an adverse reaction between the adhesive and the floorcovering backing.



#### SPECIFICATION

SIZE: **48mm X 15m**  
12 PER PACK: **B4-48/15CB**

## WOOD & LAMINATE UNDERLAYS

See underlays for wood and laminate flooring on pages 51-55

### ALL IN ONE

#### Gripperrods®

#### FEATURES

#### SPECIFICATION

All In One underlay is composed of a light 3mm polyethylene with an integral damp proof membrane whose thermal and sound insulation qualities are ideal for wood and laminate floors. Atoxic, odourless and chemically inert, All In One does not leave stains and offers an efficient resistance to pressure, repeated shocks and chemicals.



- 3mm Polyethylene
- Noise reduction of 20 dB
- Excellent thermal and shock insulator
- Integral damp proof membrane
- Integral self-adhesive fixing tape
- Odourless and non staining

SIZE: **1m X 10m**  
ROLL COVERAGE: **10m<sup>2</sup>**  
THICKNESS: **3mm**  
PACK OF 8 ROLLS: **EW310**

### SILVERLAY

#### Gripperrods®

#### FEATURES

#### SPECIFICATION

2mm polyethylene foam underlay with built-in silver foil moisture barrier and self-adhesive overlap. Silverlay wood and laminate underlay is composed of a polyethylene foam, which is laminated with an integral overlapping silver metallised polypropylene film damp proof membrane of 20 micron.

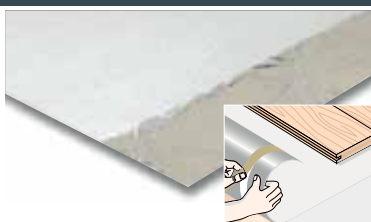

- 2mm Polyethylene
- Noise reduction of 18 dB
- Excellent thermal and shock insulator
- 10cm overlapping moisture barrier membrane
- Integral self-adhesive fixing tape
- Odourless and non staining

SIZE: **10m X 1m**  
ROLL COVERAGE: **10m<sup>2</sup>**  
THICKNESS: **2mm**  
PACK OF 8 ROLLS: **EW410**

### PLASTIFOAM WHITE

#### Gripperrods®

#### FEATURES

#### SPECIFICATION

A light polyethylene underlay suitable for use under wood or laminate floors.



- 1.8mm Polyethylene
- Noise reduction of 18 dB
- Easy to fit

SIZE: **10m X 1m**  
ROLL COVERAGE: **10m<sup>2</sup>**  
THICKNESS: **1.8mm**  
PACK OF 8 ROLLS: **EW210**  
\*The nominal roll dimensions and area have been quoted.

## FLOORING PROTECTION

### PAPER FELT - FLOOR LINING PAPER

#### Gripperrods®

#### DESCRIPTION

#### SPECIFICATION

Paper Felt prevents foam backed carpets and underlays from adhering to the sub-floor. It increases insulation and prevents dust from rising through floorboards. Available in a range of weights and roll sizes to suit all needs.



PAPER FELT - HEAVY DUTY	<b>6959</b>
PAPER FELT - MEDIUM	<b>PF2</b>
PAPER FELT - MEDIUM	<b>PF1</b>
PAPER FELT - LIGHT	<b>6950</b>

SIZE:	<b>50m X 2m</b>
COVERAGE:	<b>100m<sup>2</sup></b>
SIZE:	<b>100m X 2m</b>
COVERAGE:	<b>200m<sup>2</sup></b>
SIZE:	<b>100m X 1m</b>
COVERAGE:	<b>100m<sup>2</sup></b>
SIZE:	<b>100m X 1m</b>
COVERAGE:	<b>100m<sup>2</sup></b>

### VINYL CARPET PROTECTOR

#### Gripperrods®

#### DESCRIPTION

#### SPECIFICATION

Quality carpet protector, with studded underside, to protect carpets from soiling and wear in heavy traffic areas.



VINYL CARPET PROTECTOR: **VCPI**

RETAIL STAND AVAILABLE Pg 119

SIZE: **30m x 0.69m**  
COVERAGE: **20.7m<sup>2</sup>**  
1 roll per pack

## CLEANING

### STIKATAK® HAND CLEANING GLUE WIPES

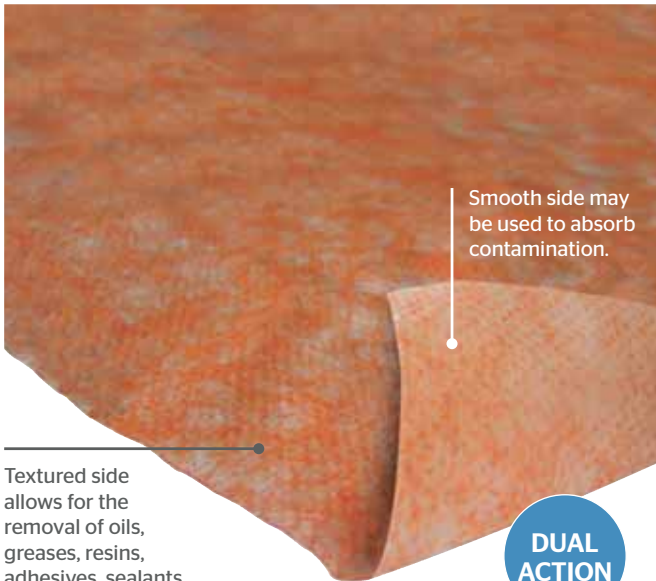

**DUAL ACTION**



Safe, heavy-duty double-sided cleaning wipes that combine a textured wipe with a hand cleaning solution. Specially formulated to remove glue, paint, grease, grout, oils and inks.

- Removes glue easily from hands
- Removes light areas of glue from carpet and flooring

**S290**  
4 x 100 wipes

### STIKATAK® CARPET STAIN REMOVER



Proven instant results on carpets and upholstery in the home, car and workplace. With the instant foaming action stains are drawn out in seconds and wiped away. No water or rinsing required - just rub with a damp cloth. Pleasant smell, anti-static, easy, safe and effortless to use.

**S240**  
400ml - 12 per pack

## WRAPPING & PACKAGING

### GRIPPERRODS® HANDYWRAP



Dispensable protective wrapping.

**T440** Refill Pack (with free handle)  
17 micron  
150m x 100mm  
10 Rolls Per Pack

### GRIPPERRODS® LAYFLAT POLYTHENE TUBING



Provides protection for rolls of carpet and vinyl.

**TL26** Layflat Polytube - 250 Gauge  
232m x 660mm (26")  
1 Roll Per Pack

**DUAL ACTION RUG ANTI-KREEP** *Gripperrods*

DESCRIPTION	SPECIFICATION
RUG ANTI-KREEP - ROLL: <b>UAK93</b>	SIZE: <b>25m X 1m</b>
Polyester Fleece with Acrylic based adhesive.	COVERAGE: <b>25m<sup>2</sup></b>
	THICKNESS: <b>2.5mm</b>
	DENSITY: <b>130gm<sup>2</sup></b>
	1 ROLL PER PACK

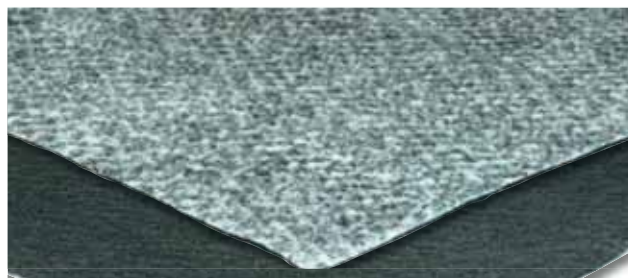

Gripperrods® Dual Action Rug Anti-Kreep prevents the movement of rugs on both carpet and hard flooring. It is suitable for use on carpet, ceramics, tiles, wood, laminates and vinyl. Leaves no staining or adhesive residue.

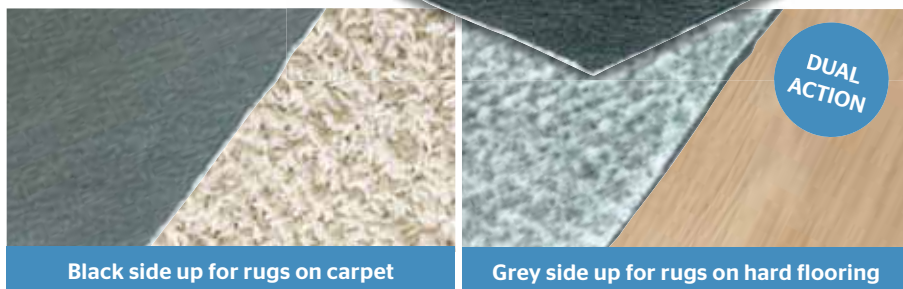

Black side up for rugs on carpet

Grey side up for rugs on hard flooring

**MERCHANDISING STANDS**

**GRIPPERRODS® ANTI-KREEP STAND**

A useful stand that not only displays the product but makes it much easier to cut to the customer's desired length. Double-sided Rug Anti-Kreep prevents the movement of rugs on both carpet and hard floorings.

- Helps to prevent accidents by holding rug in place
- Works on both carpet and hard floorings
- No staining, does not leave an adhesive residue
- Black side up for rugs on carpet, grey side up for rugs on hard flooring e.g. vinyl or laminate

*Note: stand header may differ from that shown*

**Y3** Rug Anti-Kreep Stand  
Height: 1790mm / Width: 640mm / Depth: 640mm



**GRIPPERRODS® CARPET PROTECTOR STAND**

Ideal way to display two rolls of carpet protector in a retail environment. Allows rolls to be cut to length easily.

**Y1** Carpet Protector Stand  
Height: 1320mm  
Width: 815mm  
Depth: 110m



# INSTALLATION GUIDES

## Floor Preparation

The quality of your finished flooring will depend in large part on how well the sub-floor is prepared. To achieve the best result, it's important to...

- Make sure that the sub-floor surface is smooth, clean and dry.
- Remove any nails or protruding articles.
- Completely level the floor, using a plywood layer if necessary.

## Stretch fitting a carpet

In this method, carpet is held in place using carpet grippers which are nailed to the subfloor. Carpet is stretched over the underlay and secured to the grippers.

1. Fix gripper to the floor leaving a gap between the skirting and the gripper.
2. Lay the underlay backing side up and secure the seams with tape.
3. Rough cut the carpet into place.
4. Stretch over the grippers using a knee-kicker.



Trim Master Tool



Utility Knife



Tack Hammer



Gripper Shears



Knee Kicker



Carpet Tucker



Speedcatt Carpet Tucker



Heat seam Iron



Tape Measure

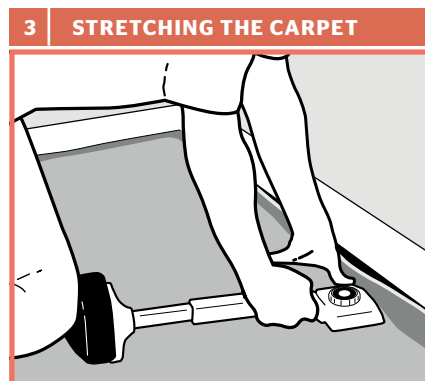
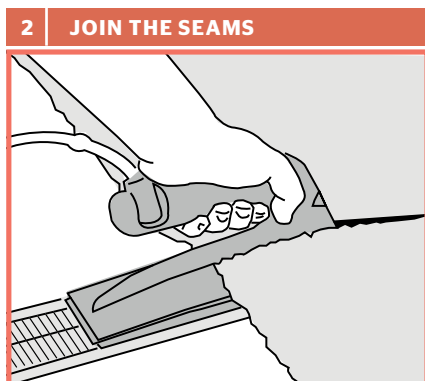
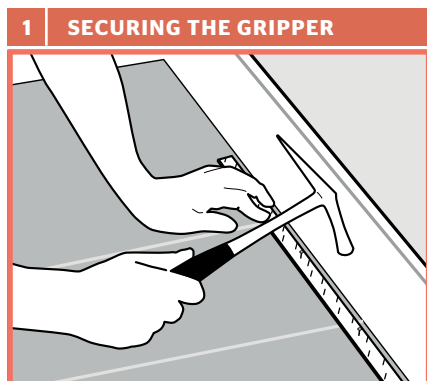

## Single and double-stick fitting a carpet

In a single-stick installation, carpet is fully adhered to the underlay with a permanent adhesive. In double-stick the underlay is also adhered to the sub-floor with a release type adhesive.

1. Apply tackifier to sub-floor using a roller, tackifier trowel or brush and allow to dry. (Omit this step for single-stick.)
2. Lay out the underlay onto the sub-floor printed side up, ensuring the underlay seams are closely butted together and run at right angles to any carpet seams. All joins should be secured with a suitable single-sided underlay tape. Care should be taken to ensure the underlay joints are level.
3. Apply carpet adhesive to the backing using a notched trowel.
4. Lay the carpet into the wet adhesive and smooth out any fullness or air bubbles with a glider.

## Fitting hard flooring

Underlays beneath hard flooring will help to support board joints and mask any unevenness in the subfloor. It will also substantially reduce impact noise and protect flooring from wear.

1. The subfloor must be level, dry, and free from dust, grease and other contaminants. Any loose floorboards or protruding nails must be hammered down.
2. The underlay should be laid foil side up. Allow a 5mm excess of underlay to run up the perimeter wall. Each roll of underlay should be closely butted-up.
3. Tape all joins with single sided waterproof tape and press firmly into place.
4. Once the flooring has been fully laid, trim the underlay to the top of the flooring.

1 APPLY TACKIFIER ADHESIVE

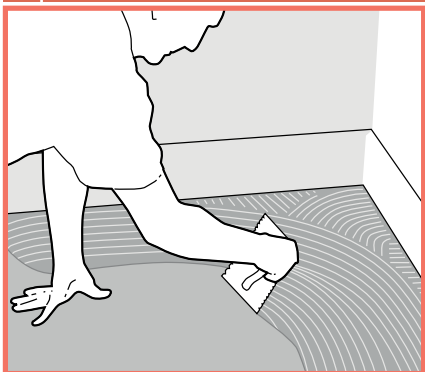

2 APPLY PERMANENT ADHESIVE

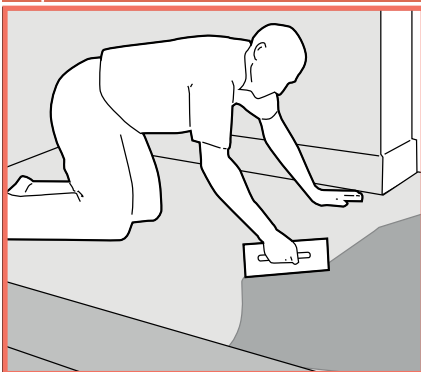

3 COMPRESS CARPET TO UNDERLAY



## RIBA Training

Our primary aim as a supporter of Continuing Professional Development is to provide fitters, specifiers and architects with the opportunity to improve their skills. We have developed RIBA and BIID approved training schemes, which offer a solid knowledge base for selecting the right underlay depending on project requirements.

We offer this training both as a traditional workshop seminar, either at our Haslingden site or on the premises of your choice; or as an online course that can be accessed worldwide.



More information can be found at:  
[www.interfloor.com/commercial/riba-biid-cpd](http://www.interfloor.com/commercial/riba-biid-cpd)  
 ...or simply scan the QR code with your phone.



# WE'RE HERE TO SUPPORT YOU

Our Tredaire® and Duralay® brands keep on growing, with consumer research showing that they are the most recognised brands of underlay in the UK. At Interfloor, we can help you reach out to your consumers to communicate all of the benefits underlay has to offer. Our dedicated Customer Service team can provide you with extensive marketing, technical and product support, ensuring you have everything needed to help customers make the right choice.

## Online & Digital Resources

Our website provides a mine of information to consumers, contractors, retailers and specifiers. You will find in-depth product information, technical specifications, an underlay selector tool, accessories and much more.

We're also happy for our customers to use our brand logos on their website and in store, providing our brand guidelines are followed. Please contact your Territory Manager or the Customer Service team who can supply:

- Tredaire®, Duralay®, Gripperrods® and Stikatak® logos
- Brand guidelines
- Product photography
- Technical specifications, also available on [interfloor.com](http://interfloor.com)
- Follow us on Facebook, Twitter and LinkedIn for regular updates, news and product launches



## Point of Sale Merchandise

**Consumers want to see first-hand what they're buying. We can support your selling with:**

- Custom-made swatch books containing your chosen range of underlays, in either A4 or A3 sizes
- Presentation folders for both Tredaire® and Duralay® underlays, outlining the benefits of each with small product samples
- Hanging samples of your chosen underlay range
- Gripperrods® carpet gripper sample tube
- Set of two standard metal edgings and nosings mounted on to counter display boards
- Premier metals counter display boards
- Premier metals estimator roll



185mm x 440mm Counter-top display



Estimator Roll

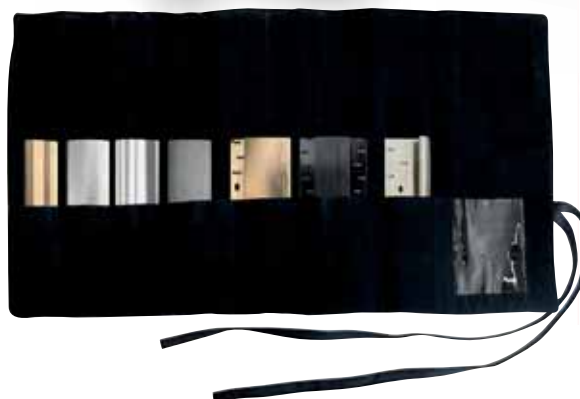

A full suite of renu® point of sale is available including hanging samples, sample wallets, sample dispenser and bus stops.

**Stockist Locator**  
Become a renu® stockist and feature in our on-line Stockist Locator.



**Sampling Service**

We send out thousands of samples every month, most commonly for swatch books, hangers and store demonstrations. If a customer wants to take home two or three samples to test, contact your Territory Manager or our Customer Service team who will be able to organise this on your behalf.



**tredaire**  
carpet underlay

**Out-of-this-world sampling and POS available**

# TRUSTED GUIDANCE FROM THE EXPERTS

As the UK's leading underlay manufacturer, we offer a wealth of support for our customers.

We can help you choose the right combination of products to cater for your client base, as well as offer additional training and marketing material.

## How to select your underlay range

Underlays have diversified considerably since their invention, reflecting the vast array of uses and applications in today's world. You may need to specify for underfloor heating systems, hard wood floors, or high-traffic commercial interiors, in addition to standard domestic carpet fittings. By choosing products that cover a variety of applications, you can provide customers with options that will suit both their project and budget.

## What does a typical range include?

- A good/better/best carpet underlay for comfort
- A carpet underlay for durability
- A carpet underlay for warmth
- A carpet underlay for impact sound
- A carpet underlay for hard flooring
- A specialist carpet underlay for underfloor heating
- A specialist underlay for contract applications

You don't need to have all of these options in stock but you should have samples available of each. This range provides different price points for the two main considerations of your customers - comfort and durability - along with specialist solutions, if needed.

## Our recommended core range

	Comfort	Durability	Warmth	Impact Sound	UFH	Hard Flooring	Contract Use
Tredaire® Colours Red	*****	****	****	*****	X	X	X
Tredaire® Premier Softwalk	*****	****	*****	*****	X	X	X
Tredaire® Premier Chromium	*****	*****	*****	*****	X	X	X
Tredaire® Brio	****	****	*****	****	X	X	X
Tredaire® System Ten	*****	*****	****	****	X	X	✓
Duralay® Durafit® 650	****	*****	***	****	✓	X	✓
Duralay® Heatflow Carpet†	****	*****	**	****	✓	X	X
Duralay® Silentfloor Gold†	--	--	--	*****	✓	✓	X
Multifit for LVT	--	--	--	*****	✓	✓	✓

† Not suitable for electric heating mats on top of structural floor.

## Our 'Good, Better, Best' recommendations

Giving customers a choice of 'good, better, best' ensures you cater for every budget and preference. We've provided our recommendations below, however if you want further information or guidance, our Territory Managers will be more than happy to help.

	Good	Better	Best
Carpet	Tredaire® Brio (4*)	Tredaire® Softwalk (5*)	Tredaire® Colours Red (6*)
	Tredaire® Xtra (4*)	Tredaire® New Supreme (5*)	Tredaire® System Ten (6*)
	Tredaire® Super MK 3 (6*)	Tredaire® Treadmore (6*)	Tredaire® Chromium (6*)
Hard Flooring	Duralay® Multitex	Duralay® Timbermate Excel	Duralay® Silentfloor Gold



## Technical & Product Support

There are very few underlay questions that we can't answer.

We provide a full range of detailed technical specifications for our underlays, all of which can be found on our website. In addition, you can find safety data sheets for sealants and adhesives.

Also online is a complete set of fitting guides for different flooring types. If you have a specific technical or application question, or you want to ask about an alternative underlay, then your first point of contact is your Territory Manager or your Customer Service contact.

In certain circumstances we can offer a troubleshooting service. Once you have spoken to your Territory Manager or Customer Service contact, you will be given the option to:

- Send a sample of the product being queried back to Interfloor to be tested for compliance against specification.
- Have a trained Interfloor fitter assess the installation.

In all circumstances the result of any analysis or assessment will be reported back to you.



### Safety Information

Complete safety data sheets for our products can be found at:

[www.interfloor.com/safety-data-sheets](http://www.interfloor.com/safety-data-sheets)

...or simply scan the QR code with your phone.



### Technical Specification

Complete technical specification for our underlays can be found at:

[interfloor.com/technical-specification](http://interfloor.com/technical-specification)

...or simply scan the QR code with your phone.

## Stock & Delivery

We are a major UK manufacturer, and all of our Tredaire® and Duralay® underlays are made in the UK at our production facility in Haslingden, Lancashire.

That gives us control over the amount of stock we keep on hand for our customers. Our minimum order is 12 rolls of underlay, though they can be made up of any mixture of underlays.



We deliver using our own vehicles, so we control the timing and the quality of the service. This also means we have the largest delivery network, by far, across the UK of any underlay manufacturer.

We don't stop at the UK. We export underlay to more than 80 countries worldwide, from Germany to Australia and from the USA to China.



## CARPET UNDERLAY

Brand	Name	Type	Stretch Fit	Single-stick	Double-stick	Part No.	Thickness -mm	Width -m <sup>2</sup>	Length -m <sup>2</sup>	Size -m <sup>2</sup>	Roll Weight -kg	Density -kg/m <sup>3</sup>
Tredaire®	Ambience	PU Foam	●			TAAMBIENCE4	9.0	1.37	11.00	15.07	19.7	145
Tredaire®	Brio	PU Foam	●			TABRIO3	8.00	1.37	11.00	15.07	11.9	100
Tredaire®	Chromium	PU Foam	●			TACHROMIUM4	9.00	1.37	11.00	15.07	25.8	180
Tredaire®	Citra	PU Foam	●			TACITRA2	11.00	1.37	11.00	15.07	24.1	145
Tredaire®	Colours Green	Sponge Rubber	●			TACOLGREEN	10.30	1.33	8.24	10.96	40.8	362
Tredaire®	Colours Red	Sponge Rubber	●			TACOLRED	11.40	1.33	8.24	10.96	44.5	357
Tredaire®	Defender	Sponge Rubber	●			TADEF3	6.10	1.37	11.00	15.07	45.5	495
Tredaire®	Dreamwalk	PU Foam	●			TADREAMWALK4	11.00	1.37	11.00	15.07	19.3	110
Duralay®	Durafit® 500	Crumb Rubber	●		●	TADURAFIT500	5.25	1.37	11.00	15.07	31.6	400
Duralay®	Durafit® 650	Crumb Rubber	●		●	TADURAFIT650	6.50	1.37	11.00	15.07	40.08	415
Tredaire®	Dynamics	Sponge Rubber	●			TADYNAMICS2	9.40	1.33	8.24	10.96	37.9	368
Tredaire®	Elite	Sponge Rubber	●			TAELITE	9.75	1.33	8.24	10.96	40.5	379
Tredaire®	Flamecheck 4	PU Foam	●		●	TAFLAMECHECK4	4.00	1.37	11.00	15.07	9.3	145
Tredaire®	Flamecheck 6	PU Foam	●		●	TAFLAMECHECK6	6.00	1.37	11.00	15.07	14.0	145
Tredaire®	Flamecheck 8	PU Foam	●		●	TAFLAMECHECK8	8.00	1.37	11.00	15.07	18.3	145
Tredaire®	FR6	PU Foam	●		●	TAFR6	6.00	1.37	11.00	15.07	18.8	200
Tredaire®	FR7	PU Foam	●		●	TAFR7	7.00	1.37	11.00	15.07	15.3	145
Tredaire®	Granduro	PU Foam	●			TAGRANURO	11.00	1.37	11.00	15.07	24.0	145
Tredaire®	Hallmark	Sponge Rubber	●			TAHK080013	9.50	1.37	8.00	10.96	42.7	410
Duralay®	Heatflow Carpet	Sponge Rubber	●			TAHEATCARPET2	6.10	1.37	7.30	10.00	30.2	495
Tredaire®	Imperium	PU Foam	●			TAIMPERIUM4	6.00	1.37	11.00	15.07	18.8	200
Tredaire®	Jazz	PU Foam	●			TAJAZZ2	9.00	1.37	11.00	15.07	19.7	145
Tredaire®	Kensington Deluxe	Crumb Rubber/Felt	●			TAKENDEL	11.00	1.30	8.43	10.96	27.4	227
Tredaire®	King	Sponge Rubber	●			TADK080013	8.30	1.33	8.24	10.96	46.6	511
Tredaire®	Lifestyle Select	Sponge Rubber	●			TALSS08013	10.20	1.33	8.24	10.96	40.9	365
Tredaire®	New Supreme	Sponge Rubber	●			TANEWSUP	8.75	1.37	8.00	10.96	37.5	391
Tredaire®	Nuvella	PU Foam	●			TANUVELLA	9.00	1.37	11.00	15.07	13.3	98
Tredaire®	Palladium	PU Foam	●			TAPALLADIUM4	10.00	1.37	11.00	15.07	28.0	180
Tredaire®	Power	Sponge Rubber	●			TAPOWER3	8.60	1.33	8.24	10.96	35.7	378
Tredaire®	Red Supreme	Sponge Rubber	●			TASH110013	8.90	1.37	11.00	15.07	46.0	343
Tredaire®	renu 11/160	PU Foam	●			TARENU11160	11.00	1.37	11.00	15.07	27.86	160
Tredaire®	renu 9/160	PU Foam	●			TARENU9160	9.00	1.37	11.00	15.07	23.0	160
Tredaire®	renu 9/120	PU Foam	●			TARENU9120	9.00	1.37	11.00	15.07	17.6	120
Unbranded	Regal 8	PU Foam	●			TAREGAL8	8.00	1.37	11.00	15.07	11.0	85
Unbranded	Regal 10	PU Foam	●			TAREGAL10	10.00	1.37	11.00	15.07	13.5	85
Unbranded	Regal 12	PU Foam	●			TAREGAL12	12.00	1.37	11.00	15.07	15.9	85
Unbranded	Regal HD 9	PU Foam	●			TAREGALHD9	9.00	1.33	11.00	15.07	17.2	120
Unbranded	Regal HD 11	PU Foam	●			TAREGALHD11	11.00	1.37	11.00	15.07	20.80	120
Unbranded	Regal UHD 10	PU Foam	●			TAREGALHD10	10.00	1.37	11.00	15.07	22.40	145
Tredaire®	Sensation	PU Foam	●			TASENSATION4	11.00	1.37	11.00	15.07	24.0	145
Tredaire®	Softwalk	PU Foam	●			TASOFTWALK4	9.00	1.37	11.00	15.07	16.0	110
Tredaire®	Super Mk 3	Crumb Rubber	●			TASUPERMK3	6.75	1.37	11.00	15.07	36.5	359
Tredaire®	System Ten**	Crumb Rubber	●	●	●	TASYSTEM10	9.20	1.37	8.00	10.96	43.8	435
Duralay®	Technics 5	Sponge Rubber	●		●	TATECH5	5.00	1.37	11.00	15.07	40.9	542
Duralay®	Technics 6	Sponge Rubber	●		●	TATECH6	6.00	1.37	11.00	15.07	47.5	525
Tredaire®	Titanium*	PU Foam	●		●	TATITANIUM3	8.00	1.37	11.00	15.07	22.5	180
Tredaire®	Treadmore	Crumb Rubber	●			TATREADMORE	7.95	1.37	8.00	10.96	34.0	390
Tredaire®	Verdanio	PU Foam	●			TAVERDANIO	10.00	1.37	11.00	15.07	16.6	110
Tredaire®	Willow Green	Sponge Rubber	●			TAWILLOW	8.40	1.37	11.00	15.07	40.9	323
Tredaire®	Xtra	Sponge Rubber	●			TAXD110013	8.25	1.37	11.00	15.07	38.3	308
Tredaire®	Zest	PU Foam	●			TAZEST3	10.00	1.37	11.00	15.07	14.9	100

We do not recommend an underlay is used with an electric mat (or dry) underfloor heating system.

\*Titanium double-stick for domestic use only, for maximum of 30m<sup>2</sup> \*\*System Ten single-stick for domestic use only, for maximum of 33m<sup>2</sup>

	Colour	Backing	Thermal -Togs	Impact Acoustic -db	Comfort	Durability	Impact Sound	Airborne Sound	Warmth	UFI	Flame Retardancy	BS Classification
	Violet	Textron® white printed stitched kraft paper	2.37	39	5★	5★	5★	2★	5★	1★		L/U
	Green	Printed Spunbonded Polyester / Twin Scrim	2.18	32	4★	4★	4★	1★	5★	1★		GD/U
	Yellow	Textron® white printed stitched kraft paper	2.26	42	5★	5★	6★	3★	5★	1★		HC/U
	Violet	Printed Spunbonded Polyester / Twin Scrim	2.90	43	6★	5★	6★	2★	6★	1★		GD/U
	Bright Green	Textron® white printed stitched kraft paper	1.47	44	6★	3★	6★	5★	3★	1★		L/U
	Bright Red	Textron® white printed stitched kraft paper	1.65	46	6★	4★	6★	6★	4★	1★		L/U
	Green	Textron® printed stitched kraft paper	0.80	31	4★	5★	4★	4★	2★	6★	5★	HC/U
	Blue	Textron® white printed stitched kraft paper	3.13	44	6★	5★	6★	2★	6★	1★		L/U
	Black	Woven Polypropylene Backing	0.88	26	3★	6★	4★	3★	2★	6★	5★	HC/U
	Black	Woven Polypropylene Backing	1.10	28	4★	6★	4★	4★	3★	4★	5★	HC/U
	Forest Green	Textron® printed stitched kraft paper	1.30	35	5★	4★	4★	4★	3★	3★	5★	L/U
	Maroon	Textron® printed stitched kraft paper	1.50	42	6★	4★	6★	5★	4★	1★		L/U
	Yellow	Printed Polyethylene with Reinforcing Mesh	1.02	26	3★	5★	4★	2★	3★	1★	6★	HC/U
	Orange	Printed Polyethylene with Reinforcing Mesh	1.58	30	4★	5★	4★	2★	4★	1★	6★	HC/U
	Red	Printed Polyethylene / Flame retardant crepe paper	1.99	34	5★	5★	4★	2★	4★	1★	6★	HC/U
	Red	Polyethylene with Reinforcing Mesh	1.68	35	4★	5★	4★	2★	4★	1★	5★	HC/U
	Yellow	Polyethylene with Reinforcing Mesh	1.99	34	4★	5★	4★	2★	4★	1★	5★	HC/U
	Yellow	Spunbonded Polyester/Printed Facing Film	2.90	43	6★	5★	6★	2★	6★	1★		L/U
	Black	Textron® printed stitched kraft paper	1.51	42	5★	5★	6★	5★	4★	1★		L/U
	Forest Green	Textron® printed stitched kraft paper	0.75	31	4★	5★	4★	4★	2★	6★		HC/U
	White	Textron® white printed stitched kraft paper	1.68	35	4★	5★	4★	2★	4★	1★		HC/U
	Red	Printed Spunbonded Polyester / Twin Scrim	2.37	39	6★	4★	6★	2★	6★	1★		L/U
	Black/Grey	Recycled pre-consumer PES polymer (Felt)	1.70	30	6★	5★	4★	4★	4★	1★		HC/U
	Black	Textron® printed stitched kraft paper	0.80	42	5★	6★	6★	6★	2★	6★		L/U
	Green	Black Spunbonded Polyester	1.51	37	6★	3★	6★	5★	4★	1★		L/U
	Dark Green	Textron® printed stitched kraft paper	1.00	39	5★	5★	5★	4★	3★	5★		L/U
	Turquoise	Spunbonded Polyester/Printed Facing Film	2.40	35	5★	4★	4★	2★	5★	1★		L/U
	Red	Textron® white printed stitched kraft paper	2.59	43	5★	5★	6★	3★	6★	1★		HC/U
	Gold	Textron® printed stitched kraft paper	1.10	37	5★	5★	5★	4★	3★	4★		L/U
	Red	Textron® printed stitched kraft paper	1.27	41	5★	5★	6★	4★	3★	3★		L/U
	Yellow	Textron® Recycled paper printed with vegetable based inks	3.05	46	6★	5★	6★	2★	6★	1★	5★	L/U
	Green	Textron® Recycled paper printed with vegetable based inks	2.54	41	5★	5★	2★	5★	5★	1★	5★	L/U
	Violet	Textron® Recycled paper printed with vegetable based inks	2.06	44	5★	5★	2★	5★	5★	1★	5★	L/U
	Blue	Printed Spunbonded Polyester	2.32	34	4★	4★	4★	1★	6★	1★		GD/U
	Green	Printed Spunbonded Polyester	2.81	37	5★	4★	5★	2★	6★	1★		GD/U
	Grey	Printed Spunbonded Polyester	3.10	45	6★	4★	6★	2★	6★	1★		L/U
	Orange	Spunbonded Polyester	2.80	41	5★	4★	6★	2★	6★	1★		L/U
	Yellow	Spunbonded Polyester	3.50	45	6★	5★	6★	2★	6★	1★		L/U
	Violet	Spunbonded Polyester	2.60	39	6★	5★	5★	2★	5★	1★		L/U
	Green	Textron® white printed stitched kraft paper	2.89	43	6★	5★	6★	2★	6★	1★		L/U
	Red	Textron® white printed stitched kraft paper	2.69	41	5★	4★	6★	2★	6★	1★	5★	L/U
	Green	Woven Polypropylene Backing	1.15	26	4★	6★	4★	4★	3★	4★		HC/U
	Black	Woven Polypropylene Backing	1.55	31	5★	6★	4★	6★	4★	1★		HC/U
	Black	Textron® printed stitched kraft paper	0.56	29	3★	5★	4★	4★	2★	6★	6★	HC/U
	Black	Textron® printed stitched kraft paper	0.66	34	4★	5★	4★	4★	2★	6★	6★	HC/U
	Grey	Printed Polyethylene with Reinforcing Mesh	2.22	39	5★	5★	5★	3★	5★	1★		HC/U
	Blue	Woven Polypropylene Backing	1.03	32	4★	6★	4★	4★	3★	5★		HC/U
	Green	Spunbonded Polyester/Printed Facing Film	2.70	41	6★	5★	6★	2★	6★	1★		L/U
	Forest Green	Textron® printed stitched kraft paper	1.10	32	5★	4★	4★	4★	3★	4★		GD/U
	Green	Textron® printed stitched kraft paper	1.51	35	4★	4★	4★	4★	4★	1★		GD/U
	Orange	Printed Spunbonded Polyester / Twin Scrim	2.64	39	6★	4★	5★	2★	6★	1★		L/U

## USAGE FOR CARPET UNDERLAYS

Brand	Name	Part No.	Lounge	Dining Room	Stairs	Hall/Landing	Bedroom	Bathroom	Office/Study	Double-stick	Single-stick
Tredaire®	Ambience	TAAMBIENCE4	•	•	•	•	•	•	•		
Tredaire®	Brio	TABRIO3	•				•	•	•		
Tredaire®	Chromium	TACHROMIUM4	•	•	•	•	•	•	•		
Tredaire®	Citra	TACITRA2	•	•	•	•	•	•	•		
Tredaire®	Colours Green	TACOLGREEN	•	•		•	•	•	•		
Tredaire®	Colours Red	TACOLRED	•	•		•	•	•	•		
Tredaire®	Defender	TADEF3	•	•	•	•	•	•	•		
Tredaire®	Dreamwalk	TADREAMWALK4	•	•	•	•	•	•	•		
Duralay®	Durafit® 500	TADURAFIT500		•	•	•		•		•	
Duralay®	Durafit® 650	TADURAFIT650		•	•	•		•		•	
Tredaire®	Dynamics	TADYNAMICS2	•	•		•	•	•	•		
Tredaire®	Elite	TAEELITE	•	•		•	•	•	•		
Tredaire®	Flamecheck 4	TAFLAMECHECK4	•	•	•	•	•	•	•	•	
Tredaire®	Flamecheck 6	TAFLAMECHECK6	•	•	•	•	•	•	•	•	
Tredaire®	Flamecheck 8	TAFLAMECHECK8	•	•	•	•	•	•	•	•	
Tredaire®	FR6	TAFR6	•	•	•	•	•	•	•	•	
Tredaire®	FR7	TAFR7	•	•	•	•	•	•	•	•	
Tredaire®	Granduro	TAGRANURO	•	•		•	•	•	•		
Tredaire®	Hallmark	TAHK080013	•	•	•	•	•	•	•		
Duralay®	Heatflow Carpet	TAHEATCARPET2	•	•		•	•	•	•		
Tredaire®	Imperium	TAIMPERIUM4	•	•	•	•	•	•	•		
Tredaire®	Jazz	TAJAZZ2	•	•			•	•	•		
Tredaire®	Kensington Deluxe	TAKENDEL	•	•	•	•		•	•		
Tredaire®	King	TADK080013	•	•	•	•	•	•	•		
Tredaire®	Lifestyle Select	TALSS08013	•	•		•	•	•	•		
Tredaire®	New Supreme	TANEWSUP	•		•	•	•	•	•		
Tredaire®	Nuvella	TANUVELLA	•				•	•	•		
Tredaire®	Palladium	TAPALLADIUM4	•	•	•	•	•	•	•		
Tredaire®	Power	TAPOWER3	•	•	•	•	•	•	•		
Tredaire®	Red Supreme	TASH110013	•		•		•	•	•		
Tredaire®	renu® 11/160	TARENU11160	•	•	•	•	•	•	•		
Tredaire®	renu® 9/160	TARENU9160	•	•	•	•	•	•	•		
Tredaire®	renu® 9/120	TARENU9120	•	•	•	•	•	•	•		
Unbranded	Regal 8	TAREGAL8	•				•	•	•		
Unbranded	Regal 10	TAREGAL10	•				•	•	•		
Unbranded	Regal 12	TAREGAL12	•				•	•	•		
Unbranded	Regal HD 9	TAREGALHD9	•	•	•	•	•	•	•		
Unbranded	Regal HD 11	TAREGALHD11	•	•	•	•	•	•	•		
Unbranded	Regal UHD 10	TAREGALHD10	•	•	•	•	•	•	•		
Tredaire®	Sensation	TASENSATION4	•	•	•	•	•	•	•		
Tredaire®	Softwalk	TASOFTWALK4	•	•	•	•	•	•	•		
Tredaire®	Super Mk 3	TAM3110013	•	•	•	•		•	•		
Tredaire®	System Ten**	TASYS10INT	•	•	•	•		•	•	•	•
Duralay®	Technics 5	TATECH5		•	•	•		•	•	•	
Duralay®	Technics 6	TATECH6		•	•	•		•	•	•	
Tredaire®	Titanium*	TATITANIUM3	•	•	•	•	•	•	•	•	
Tredaire®	Treadmore	TATREADMORE	•	•	•	•		•	•		
Tredaire®	Verdanio	TAVERDANIO	•	•	•	•	•	•	•		
Tredaire®	Willow Green	TAWILLOW	•		•		•	•	•		
Tredaire®	Xtra	TAXD110013	•				•	•	•		
Tredaire®	Zest	TAZEST3	•	•			•	•	•		

\*Titanium double-stick for domestic use only, for maximum of 30m<sup>2</sup> \*\*System Ten single-stick for domestic use only, for maximum of 33m<sup>2</sup>

## WOOD &amp; LAMINATE

Brand	Name	Type	Part No.	Thickness - mm	Width - m <sup>2</sup>	Length - m <sup>2</sup>	Size - m <sup>2</sup>	Roll Weight - kg	Density - kg/m <sup>3</sup>
Duralay®	Heatflow Wood & Laminate	Sponge Rubber	TAHEATWOOD	3.00	1.37	11.00	15.07	36.2	802
Duralay®	Multitex	Sponge Rubber	TADM146068	3.60	0.685	14.60	10.00	25.4	706
Duralay®	Silentfloor Gold	Sponge Rubber	TASILGOLD	4.20	1.37	7.30	10.00	29.9	710
Duralay®	Timbermate Excel	Sponge Rubber	TATEX11013	3.60	1.37	11.00	15.07	38.3	707
Duralay®	Timbermate Excel DIY	Sponge Rubber	TATXL14668	3.60	0.685	14.60	10.00	25.6	707
Sonixx®	Resilient 250	Sponge Rubber	TARS250	2.50	1.37	7.30	10.00	24.0	960
Sonixx®	Soundsure 400	Rubber Crumb	TASS400A	4.00	1.37	11.00	15.07	24.9	400

## WOOD &amp; LAMINATE

Brand	Name	Type	Backing	Stone	Thermal - Togs	Impact Acoustic - db	Impact Sound	Airborne Sound	Warmth	UFH	Moisture
Duralay®	Heatflow Wood & Laminate	Sponge Rubber	Printed Textron	57	0.35	21	4★	1★	5★	6★	N/A
Duralay®	Multitex	Sponge Rubber	Spunbonded Polyester	57	0.57	23	6★	3★	5★	1★	N/A
Duralay®	Silentfloor Gold	Sponge Rubber	Gold, Printed Vapourstop Membrane	53	0.33	24	6★	5★	3★	1★	6★
Duralay®	Timbermate Excel	Sponge Rubber	Silver, Printed Vapourstop Membrane	56	0.55	23	6★	6★	4★	1★	6★
Duralay®	Timbermate Excel DIY	Sponge Rubber	Silver, Printed Vapourstop Membrane	56	0.55	23	5★	1★	5★	1★	6★
Sonixx®	Resilient 250	Sponge Rubber	Black Polypropylene	-	0.23	19	3★	6★	3★	6★	N/A
Sonixx®	Soundsure 400	Rubber Crumb	Spunbonded Polyester	-	0.95	24	6★	5★	4★	1★	N/A

We do not recommend an underlay is used with an electric mat (or dry) underfloor heating system.

## LVT

Brand	Name	Type	Part No.	Thickness - mm	Width - m <sup>2</sup>	Length - m <sup>2</sup>	Size - m <sup>2</sup>	Roll Weight - kg	Density - kg/m <sup>3</sup>
LVT	Low-Grab Underlay	Sponge Rubber	TALVTLLOWGRAB	1.50	1.00	10.00	10.00	15.0	1000
LVT	Dry-Back Underlay	Sponge Rubber	TALVTDYBACK	1.80	1.00	6.5	6.50	16.25	1444
LVT	Multi-Fit Underlay	Sponge Rubber	TALVTMULTIFIT	1.50	1.37	7.30	10.00	25.0	1667
Sonixx®	Resilient 250	Sponge Rubber	TARS250	2.50	1.37	7.30	10.00	24.0	960

## LVT

Brand	Name	Type	Colour	Backing	Stone	Thermal - Togs	Impact Acoustic - db	Impact Sound	Airborne Sound	Warmth	UFH	Moisture
LVT	Low-Grab Underlay	Sponge Rubber	Blue	Low Grab	-	0.10	17	6★	2★	N/A	6★	N/A
LVT	Dry-Back Underlay	Sponge Rubber	Green	High tack adhesive with protective film	-	0.10	15	6★	4★	N/A	6★	N/A
LVT	Multi-Fit Underlay	Sponge Rubber	Black	Spunbonded Polyester	-	0.12	18	6★	4★	N/A	6★	N/A
Sonixx®	Resilient 250	Sponge Rubber	Black	Polypropylene	-	0.23	19	6★	5★	4★	6★	N/A



# interfloor

## Interfloor Limited

Broadway, Haslingden, Rossendale,  
Lancashire, BB4 4LS United Kingdom

## Enquiries

Tel: +44 (0)1706 238810  
sales@interfloor.com

## International Sales

Tel: +44 (0) 1706 238825  
international@interfloor.com

[interfloor.com](http://interfloor.com)

